



# SPECIFICATION

SPEC. No. \_\_\_\_\_

DATE : \_\_\_\_\_

Customer  
  
\_\_\_\_\_

CUSTOMER'S PRODUCT NAME

TDK PRODUCT NAME  
MULTILAYER CERAMIC CHIP CAPACITORS  
CGA2, CGA3, CGA4, CGA5, CGA6 Type/  
6.3V to 630V/COG, X7R, Characteristics

Please sign and return this specification to TDK representatives. If orders are placed without this returned documentation, we must consider you found the specification acceptable.

## THIS SPECIFICATION IS RECEIVED

DATE: \_\_\_\_\_ YEAR \_\_\_\_\_ MONTH \_\_\_\_\_ DAY \_\_\_\_\_

TDK-EPC Corporation  
1-13-1, Nihonbashi, Chuo-ku, Tokyo  
103-0027, Japan

### ENGINEERING

ISSUED	CHECKED	APPROVED
DATE	DATE	DATE

Sales Office \_\_\_\_\_

Sales Tel. \_\_\_\_\_ ( ) \_\_\_\_\_

PRODUCT CLASSIFICATION  
CODE

040320

## 1. SCOPE

This specification is applicable to chip type multilayer ceramic capacitors with a priority over other relevant specifications. Production places defined in this specification shall be TDK-EPC Corporation Japan, TDK-EPC HONG KONG LIMITED, TDK (Suzhou) Co., Ltd, TDK (Malaysia) Sdn. Bhd and TDK Components U.S.A. Inc.

### EXPLANATORY NOTE:

This specification warrants the quality of the TDK ceramic chip capacitor. The product should be evaluated and confirmed in your product before use. If the use of the product exceeds the bounds of this specification, we can not guarantee its quality and/or reliability.

## 2. CODE CONSTRUCTION

(Example)  $\frac{CGA}{(1)}$   $\frac{4}{(2)}$   $\frac{J}{(3)}$   $\frac{3}{(4)}$   $\frac{X7R}{(5)}$   $\frac{1\ C}{(6)}$   $\frac{225}{(7)}$   $\frac{K}{(8)}$   $\frac{T}{(9)}$

### 1. Type

CGA = automotive grade

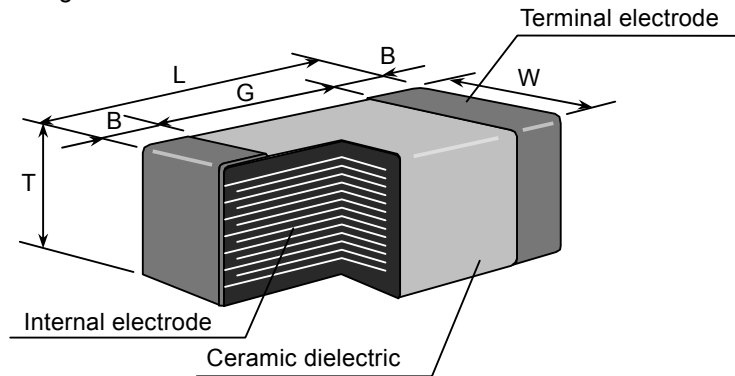

### 2. Case size

Please refer to product list for the dimension of each product. See Section 9 for inside structure and material.

### 3. Thickness

\* As for dimension tolerance, please contact with our sales representative.

Thickness	Dimension (mm)
B	0.50
C	0.60
E	0.80
F	0.85
H	1.15
J	1.25
K	1.30
L	1.60
M	2.00
N	2.30
P	2.50

4. Life Test Voltage Condition  
(Max. operating Temp./1000h)

Sign	Condition
1	Rated Voltage x 1
2	Rated Voltage x 2
3	Rated Voltage x 1.5
4	Rated Voltage x 1.2

5. Temperature Characteristics (Details are shown in Section 8 Performance, No. 7 & 8.)

6. Rated Voltage

Symbol	Rated Voltage
2 J	630 V DC
2 E	250 V DC
2 A	100 V DC
1 H	50 V DC
1 E	25 V DC
1 C	16 V DC
1 A	10 V DC
0 J	6.3 V DC

7. Rated Capacitance

Stated in three digits and in units of pico farads (pF). The first and second digits identify the first and second significant figures of the capacitance, the third digit identifies the multiplier. R is designated for a decimal point.

Example 2R2 → 2.2pF  
225 → 2,200,000pF

8. Capacitance Tolerance

Symbol	Tolerance	Capacitance
C	± 0.25 pF	10pF and under
D	± 0.5 pF	
J	± 5 %	Over 10pF
K	± 10 %	
M	± 20 %	

9. Packaging

Symbol	Packaging
B	Bulk
T	Taping

### 3. RATED CAPACITANCE AND TOLERANCE

#### 1. Standard combination of rated capacitance and tolerances

Class	Temperature Characteristics	Capacitance tolerance		Rated capacitance
1	C0G	10pF and under	C ( $\pm 0.25\text{pF}$ )	0.5, 1, 1.5, 2, 2.2, 3, 3.3, 4, 4.7, 5
			D ( $\pm 0.5\text{pF}$ )	6, 6.8, 7, 8, 9, 10
		12pF to 10,000pF	J ( $\pm 5\%$ ) K ( $\pm 10\%$ )	E – 12 series
		Over 10,000pF	K ( $\pm 10\%$ )	E – 6 series
2	X7R X8R	10uF and under	K ( $\pm 10\%$ )	E – 6 series
		Over 10uF	M ( $\pm 20\%$ )	

#### 2. Capacitance Step in E series

E series	Capacitance Step											
E-6	1.0	1.5	2.2	3.3	4.7	6.8						
E-12	1.0	1.2	1.5	1.8	2.2	2.7	3.3	3.9	4.7	5.6	6.8	8.2

#### 4. OPERATING TEMPERATURE RANGE

T.C.	Min. operating Temperature	Max. operating Temperature	Reference Temperature
C0G X7R	-55°C	125°C	25°C
X8R	-55°C	150°C	25°C

#### 5. STORING CONDITION AND TERM

5 to 40°C at 20 to 70%RH  
6 months Max.

#### 6. P.C. BOARD

When mounting on an aluminum substrate, large case sizes such as C3225, types are more likely to be affected by heat stress from the substrate. Please inquire separate specification for the large case sizes when mounted on the substrate.

#### 7. INDUSTRIAL WASTE DISPOSAL

Dispose this product as industrial waste in accordance with local Industrial Waste Laws.

## 8. PERFORMANCE

No.	Item	Performance	Test or inspection method																	
1	External Appearance	No defects which may affect performance.	Inspect with magnifying glass (3×).																	
2	Insulation Resistance	10,000MΩ or 500MΩ·μF min. (As for the capacitors of rated voltage 16V DC and the item below, 10,000 MΩ or 100MΩ·μF min.,) whichever smaller.	Apply rated voltage for 60s. As for the rated voltage 630V DC, apply 500V.																	
3	Voltage Proof	Withstand test voltage without insulation breakdown or other damage.	<table border="1"> <thead> <tr> <th>Class</th> <th>Rated voltage</th> <th>Apply voltage</th> </tr> </thead> <tbody> <tr> <td rowspan="2">Class 1</td> <td>100V and under</td> <td>3 × rated voltage</td> </tr> <tr> <td>Over 100V</td> <td>1.5 × rated voltage</td> </tr> <tr> <td rowspan="2">Class 2</td> <td>100V and under</td> <td>2.5 × rated voltage</td> </tr> <tr> <td>Over 100V</td> <td>1.5 × rated voltage</td> </tr> </tbody> </table> <p>Above DC voltage shall be applied for 1 to 5s. Charge / discharge current shall not exceed 50mA.</p>	Class	Rated voltage	Apply voltage	Class 1	100V and under	3 × rated voltage	Over 100V	1.5 × rated voltage	Class 2	100V and under	2.5 × rated voltage	Over 100V	1.5 × rated voltage				
Class	Rated voltage	Apply voltage																		
Class 1	100V and under	3 × rated voltage																		
	Over 100V	1.5 × rated voltage																		
Class 2	100V and under	2.5 × rated voltage																		
	Over 100V	1.5 × rated voltage																		
4	Capacitance	Within the specified tolerance.	<table border="1"> <thead> <tr> <th>Class</th> <th>Capacitance</th> <th>Measuring frequency</th> <th>Measuring voltage</th> </tr> </thead> <tbody> <tr> <td rowspan="2">Class 1</td> <td>1000pF and under</td> <td>1MHz±10%</td> <td rowspan="2">0.5-5Vrms.</td> </tr> <tr> <td>Over 1000pF</td> <td>1kHz±10%</td> </tr> <tr> <td rowspan="2">Class 2</td> <td>10uF and under</td> <td>1kHz±10%</td> <td>1.0±0.2Vrms.</td> </tr> <tr> <td>Over 10uF</td> <td>120Hz±20%</td> <td>0.5±0.2Vrms.</td> </tr> </tbody> </table>	Class	Capacitance	Measuring frequency	Measuring voltage	Class 1	1000pF and under	1MHz±10%	0.5-5Vrms.	Over 1000pF	1kHz±10%	Class 2	10uF and under	1kHz±10%	1.0±0.2Vrms.	Over 10uF	120Hz±20%	0.5±0.2Vrms.
Class	Capacitance	Measuring frequency	Measuring voltage																	
Class 1	1000pF and under	1MHz±10%	0.5-5Vrms.																	
	Over 1000pF	1kHz±10%																		
Class 2	10uF and under	1kHz±10%	1.0±0.2Vrms.																	
	Over 10uF	120Hz±20%	0.5±0.2Vrms.																	
5	Q (Class 1)	<table border="1"> <thead> <tr> <th>Capacitance</th> <th>Q</th> </tr> </thead> <tbody> <tr> <td>30pF and over</td> <td>1,000 min.</td> </tr> <tr> <td>Under 30pF</td> <td>400+20×C min.</td> </tr> </tbody> </table> <p>C : Rated capacitance (pF)</p>	Capacitance	Q	30pF and over	1,000 min.	Under 30pF	400+20×C min.	See No.4 in this table for measuring condition.											
Capacitance	Q																			
30pF and over	1,000 min.																			
Under 30pF	400+20×C min.																			
6	Dissipation Factor (Class 2)	0.03 max. 0.05 max. 0.075 max. 0.1 max.	See No.4 in this table for measuring condition.																	
7	Temperature Characteristics of Capacitance (Class1)	<table border="1"> <thead> <tr> <th>T.C.</th> <th>Temperature Coefficient</th> </tr> </thead> <tbody> <tr> <td>COG</td> <td>0 ± 30 (ppm/°C)</td> </tr> </tbody> </table> <p>Capacitance drift within ± 0.2% or ± 0.05pF, whichever larger.</p>	T.C.	Temperature Coefficient	COG	0 ± 30 (ppm/°C)	<p>Temperature coefficient shall be calculated based on values at 25°C and 85°C temperature.</p> <p>Measuring temperature below 20°C shall be -10°C and -25°C.</p>													
T.C.	Temperature Coefficient																			
COG	0 ± 30 (ppm/°C)																			

(8. Performance, continued)

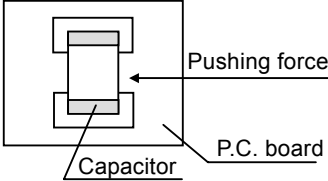
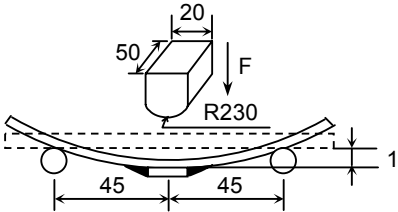
No.	Item	Performance	Test or inspection method										
8	Temperature Characteristics of Capacitance (Class 2)	<p style="text-align: center;">Capacitance Change (%)</p> <hr/> <p style="text-align: center;">No voltage applied</p> <hr/> <p style="text-align: center;">X7R: <math>\pm 15</math> X8R: <math>\pm 15</math></p> <hr/>	<p>Capacitance shall be measured by the steps shown in the following table after thermal equilibrium is obtained for each step.  <math>\Delta C</math> be calculated ref. STEP3 reading</p> <table border="1" style="margin-left: auto; margin-right: auto;"> <thead> <tr> <th data-bbox="987 359 1057 428">Step</th> <th data-bbox="1057 359 1409 428">Temperature(°C)</th> </tr> </thead> <tbody> <tr> <td data-bbox="987 428 1057 485">1</td> <td data-bbox="1057 428 1409 485">Reference temp. <math>\pm 2</math></td> </tr> <tr> <td data-bbox="987 485 1057 541">2</td> <td data-bbox="1057 485 1409 541">Min. operating temp. <math>\pm 3</math></td> </tr> <tr> <td data-bbox="987 541 1057 598">3</td> <td data-bbox="1057 541 1409 598">Reference temp. <math>\pm 2</math></td> </tr> <tr> <td data-bbox="987 598 1057 655">4</td> <td data-bbox="1057 598 1409 655">Max. operating temp. <math>\pm 2</math></td> </tr> </tbody> </table> <p>Measuring voltage: 0.1, 0.2, 0.5, 1.0Vrms.</p>	Step	Temperature(°C)	1	Reference temp. $\pm 2$	2	Min. operating temp. $\pm 3$	3	Reference temp. $\pm 2$	4	Max. operating temp. $\pm 2$
Step	Temperature(°C)												
1	Reference temp. $\pm 2$												
2	Min. operating temp. $\pm 3$												
3	Reference temp. $\pm 2$												
4	Max. operating temp. $\pm 2$												
9	Robustness of Terminations	No sign of termination coming off, breakage of ceramic, or other abnormal signs.	<p>Reflow solder the capacitor on P.C. board (shown in Appendix 1a or Appendix 1b) and apply a pushing force of 2N (CGA2) or 17.7N (CGA3, CGA4, CGA5, CGA6) with <math>10 \pm 1</math>s.</p>  <p>The diagram shows a top-down view of a capacitor mounted on a P.C. board. A horizontal arrow labeled 'Pushing force' points to the right, indicating the direction of the applied force. The capacitor is labeled 'Capacitor' and the board is labeled 'P.C. board'.</p>										
10	Bending	No mechanical damage.	<p>Reflow solder the capacitors on P.C. board (shown in Appendix 2a or Appendix 2b) and bend it for 1mm.</p>  <p>The diagram shows a side view of a capacitor on a P.C. board being bent. The capacitor has a height of 50 mm and a width of 20 mm. A downward force 'F' is applied to the top of the capacitor. The board is bent with a radius of R230. The distance from the center of the capacitor to the ends of the board is 45 mm. The board thickness is 1 mm.</p> <p style="text-align: right;">(Unit: mm)</p>										

## (8. Performance, continued)

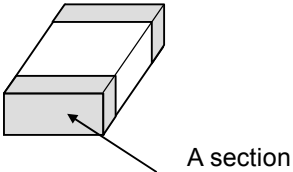
No.	Item	Performance	Test or inspection method																																	
11	Solderability	<p>New solder to cover over 75% of termination. 25% may have pin holes or rough spots but not concentrated in one spot. Ceramic surface of "A sections" shall not be exposed due to melting or shifting of termination material.</p> 	<p>Completely soak both terminations in solder at <math>235\pm 5^{\circ}\text{C}</math> for <math>2\pm 0.5\text{s}</math>.</p> <p>Solder : H63A (JIS Z 3282)</p> <p>Flux : Isopropyl alcohol (JIS K 8839) Rosin (JIS K 5902) 25% solid solution.</p>																																	
12	Resistance to solder heat	<table border="1"> <tr> <td colspan="2">External appearance</td> <td>No cracks are allowed and terminations shall be covered at least 60% with new solder.</td> </tr> <tr> <td colspan="2">Capacitance</td> <td> <table border="1"> <tr> <td colspan="2">Characteristics</td> <td>Change from the value before test</td> </tr> <tr> <td>Class 1</td> <td>C0G</td> <td>Capacitance drift within <math>\pm 2.5\%</math> or <math>\pm 0.25\text{pF}</math>, whichever larger.</td> </tr> <tr> <td>Class 2</td> <td>X7R X8R</td> <td><math>\pm 7.5\%</math></td> </tr> </table> </td> </tr> <tr> <td colspan="2">Q (Class 1)</td> <td> <table border="1"> <tr> <td>Capacitance</td> <td>Q</td> </tr> <tr> <td>30pF and over</td> <td>1,000 min.</td> </tr> <tr> <td>Under 30pF</td> <td><math>400+20\times C</math> min.</td> </tr> </table> <p style="text-align: center;">C : Rated capacitance (pF)</p> </td> </tr> <tr> <td colspan="2">D.F. (Class 2)</td> <td>Meet the initial spec.</td> </tr> <tr> <td colspan="2">Insulation Resistance</td> <td>Meet the initial spec.</td> </tr> <tr> <td colspan="2">Voltage proof</td> <td>No insulation breakdown or other damage.</td> </tr> </table>	External appearance		No cracks are allowed and terminations shall be covered at least 60% with new solder.	Capacitance		<table border="1"> <tr> <td colspan="2">Characteristics</td> <td>Change from the value before test</td> </tr> <tr> <td>Class 1</td> <td>C0G</td> <td>Capacitance drift within <math>\pm 2.5\%</math> or <math>\pm 0.25\text{pF}</math>, whichever larger.</td> </tr> <tr> <td>Class 2</td> <td>X7R X8R</td> <td><math>\pm 7.5\%</math></td> </tr> </table>	Characteristics		Change from the value before test	Class 1	C0G	Capacitance drift within $\pm 2.5\%$ or $\pm 0.25\text{pF}$ , whichever larger.	Class 2	X7R X8R	$\pm 7.5\%$	Q (Class 1)		<table border="1"> <tr> <td>Capacitance</td> <td>Q</td> </tr> <tr> <td>30pF and over</td> <td>1,000 min.</td> </tr> <tr> <td>Under 30pF</td> <td><math>400+20\times C</math> min.</td> </tr> </table> <p style="text-align: center;">C : Rated capacitance (pF)</p>	Capacitance	Q	30pF and over	1,000 min.	Under 30pF	$400+20\times C$ min.	D.F. (Class 2)		Meet the initial spec.	Insulation Resistance		Meet the initial spec.	Voltage proof		No insulation breakdown or other damage.	<p>Completely soak both terminations in solder at <math>260\pm 5^{\circ}\text{C}</math> for <math>5\pm 1\text{s}</math>.</p> <p>Preheating condition Temp.: <math>150\pm 10^{\circ}\text{C}</math> Time: 1 to 2min.</p> <p>Flux : Isopropyl alcohol (JIS K 8839) Rosin (JIS K 5902) 25% solid solution.</p> <p>Solder : H63A (JIS Z 3282)</p> <p>Leave the capacitor in ambient conditions for 6 to 24h (Class 1) or <math>24\pm 2\text{h}</math> (Class 2) before measurement.</p>
External appearance		No cracks are allowed and terminations shall be covered at least 60% with new solder.																																		
Capacitance		<table border="1"> <tr> <td colspan="2">Characteristics</td> <td>Change from the value before test</td> </tr> <tr> <td>Class 1</td> <td>C0G</td> <td>Capacitance drift within <math>\pm 2.5\%</math> or <math>\pm 0.25\text{pF}</math>, whichever larger.</td> </tr> <tr> <td>Class 2</td> <td>X7R X8R</td> <td><math>\pm 7.5\%</math></td> </tr> </table>	Characteristics		Change from the value before test	Class 1	C0G	Capacitance drift within $\pm 2.5\%$ or $\pm 0.25\text{pF}$ , whichever larger.	Class 2	X7R X8R	$\pm 7.5\%$																									
Characteristics		Change from the value before test																																		
Class 1	C0G	Capacitance drift within $\pm 2.5\%$ or $\pm 0.25\text{pF}$ , whichever larger.																																		
Class 2	X7R X8R	$\pm 7.5\%$																																		
Q (Class 1)		<table border="1"> <tr> <td>Capacitance</td> <td>Q</td> </tr> <tr> <td>30pF and over</td> <td>1,000 min.</td> </tr> <tr> <td>Under 30pF</td> <td><math>400+20\times C</math> min.</td> </tr> </table> <p style="text-align: center;">C : Rated capacitance (pF)</p>	Capacitance	Q	30pF and over	1,000 min.	Under 30pF	$400+20\times C$ min.																												
Capacitance	Q																																			
30pF and over	1,000 min.																																			
Under 30pF	$400+20\times C$ min.																																			
D.F. (Class 2)		Meet the initial spec.																																		
Insulation Resistance		Meet the initial spec.																																		
Voltage proof		No insulation breakdown or other damage.																																		

## (8. Performance, continued)

No.	Item		Performance		Test or inspection method														
13	Vibration	External appearance	No mechanical damage.		Reflow solder the capacitor on P.C. board (shown in Appendix1) before testing.  Vibrate the capacitor with following conditions.  Applied force: 5G max. Frequency: 10-2000Hz Duration: 20 min. Cycle : 12 cycles														
		Capacitance	Characteristics			Change from the value before test													
			Class 1	COG		Capacitance drift within $\pm 2.5\%$ or $\pm 0.25\text{pF}$ , whichever larger.													
			Class 2	X7R X8R		$\pm 7.5\%$													
Q (Class 1)	Capacitance	Q																	
	30pF and over	1,000 min.																	
D.F. (Class 2)	Under 30pF	400+20×C min.																	
	C : Rated capacitance (pF)																		
14	Temperature cycle	External appearance	No mechanical damage.		Reflow solder the capacitor on P.C. board (shown in Appendix 1a or Appendix 1b) before testing.  Expose the capacitor in the conditions step 1 through step 4 and repeat 1000 times consecutively.  Leave the capacitor in ambient conditions for 6 to 24h (Class 1) or 24±2h (Class 2) before measurement.														
		Capacitance	Characteristics			Change from the value before test													
			Class 1	COG		Capacitance drift within $\pm 2.5\%$ or $\pm 0.25\text{pF}$ , whichever larger.													
			Class 2	X7R X8R		$\pm 7.5\%$													
		Q (Class 1)	Capacitance	Q															
			30pF and over	1,000 min.															
		D.F. (Class 2)	Under 30pF	400+20×C min.															
			C : Rated capacitance (pF)																
Insulation Resistance	Meet the initial spec.		<table border="1"> <thead> <tr> <th>Step</th> <th>Temperature(°C)</th> <th>Time (min.)</th> </tr> </thead> <tbody> <tr> <td>1</td> <td>Min. operating temp. <math>\pm 3</math></td> <td>30 <math>\pm</math> 3</td> </tr> <tr> <td>2</td> <td>Reference Temp. <math>\pm 2</math></td> <td>2 - 5</td> </tr> <tr> <td>3</td> <td>Max. operating temp. <math>\pm 2</math></td> <td>30 <math>\pm</math> 2</td> </tr> <tr> <td>4</td> <td>Reference Temp. <math>\pm 2</math></td> <td>2 - 5</td> </tr> </tbody> </table>		Step	Temperature(°C)	Time (min.)	1	Min. operating temp. $\pm 3$	30 $\pm$ 3	2	Reference Temp. $\pm 2$	2 - 5	3	Max. operating temp. $\pm 2$	30 $\pm$ 2	4	Reference Temp. $\pm 2$	2 - 5
	Step	Temperature(°C)	Time (min.)																
1	Min. operating temp. $\pm 3$	30 $\pm$ 3																	
2	Reference Temp. $\pm 2$	2 - 5																	
3	Max. operating temp. $\pm 2$	30 $\pm$ 2																	
4	Reference Temp. $\pm 2$	2 - 5																	
Voltage proof	Meet the initial spec.																		
	No insulation breakdown or other damage.																		

## (8. Performed, continued)

No.	Item		Performance	Test or inspection method									
15	Moisture Resistance	External appearance	No mechanical damage.	<p>Reflow solder the capacitor on P.C. board (shown in Appendix 1a or Appendix 1b) before testing.</p> <p>Apply the rated voltage at temperature 85°C and 85%RH for 1000 +24,0h.</p> <p>Charge/discharge current shall not exceed 50mA.</p> <p>Leave the capacitor in ambient conditions for 6 to 24h (Class 1) or 24±2h (Class 2) before measurement.</p> <p>Voltage conditioning (only for Class 2) Voltage treat the capacitor under testing temperature and voltage for 1 hour.</p> <p>Leave the capacitor in ambient conditions for 24±2h before measurement.</p> <p>Use this measurement for initial value.</p>									
		Capacitance	<table border="1"> <thead> <tr> <th colspan="2">Characteristics</th> <th>Change from the value before test</th> </tr> </thead> <tbody> <tr> <td>Class 1</td> <td>C0G</td> <td>Capacitance drift within ± 7.5% or ± 0.75pF, whichever larger.</td> </tr> <tr> <td>Class 2</td> <td>X7R X8R</td> <td>± 12.5 %</td> </tr> </tbody> </table>		Characteristics		Change from the value before test	Class 1	C0G	Capacitance drift within ± 7.5% or ± 0.75pF, whichever larger.	Class 2	X7R X8R	± 12.5 %
			Characteristics		Change from the value before test								
			Class 1		C0G	Capacitance drift within ± 7.5% or ± 0.75pF, whichever larger.							
		Class 2	X7R X8R		± 12.5 %								
Q (Class 1)	<table border="1"> <thead> <tr> <th>Capacitance</th> <th>Q</th> </tr> </thead> <tbody> <tr> <td>30pF and over</td> <td>200 and over</td> </tr> <tr> <td>Under 30pF</td> <td>100+10/3×C min.</td> </tr> </tbody> </table> <p style="text-align: center;">C : Rated capacitance (pF)</p>	Capacitance	Q	30pF and over	200 and over	Under 30pF	100+10/3×C min.						
	Capacitance	Q											
30pF and over	200 and over												
Under 30pF	100+10/3×C min.												
D.F. (Class 2)	Characteristics X7R: 200% of initial spec. max. X8R: 200% of initial spec. max.												
Insulation Resistance	500MΩ or 25MΩ·μF min. (As for the capacitors of rated voltage 16V DC and item below, 500MΩ or 5MΩ·μF min.,) whichever smaller.												
16	Life	External appearance	No mechanical damage.	<p>Reflow solder the capacitor on P.C. board (shown in Appendix 1a or Appendix 1b) before testing.</p> <p>Test condition : maximum operating temperature ±2°C for 1,000 +48,0hAs for applied voltage, please refer to (Section 2, #4 Life Test Voltage Condition).</p> <p>Charge/discharge current shall not exceed 50mA.</p> <p>Leave the capacitor in ambient conditions for 6 to 24h (Class 1) or 24±2h (Class 2) before measurement.</p> <p>Voltage conditioning: Voltage treat the capacitors under testing temperature and voltage for 1 hour.</p> <p>Leave the capacitor in ambient conditions on for 24±2h before measurement.</p> <p>Use this measurement for initial value.</p>									
		Capacitance	<table border="1"> <thead> <tr> <th colspan="2">Characteristics</th> <th>Change from the value before test</th> </tr> </thead> <tbody> <tr> <td>Class 1</td> <td>C0G</td> <td>Capacitance drift within ± 7.5% or ± 0.75pF, whichever larger.</td> </tr> <tr> <td>Class 2</td> <td>X7R X8R</td> <td>± 15 %</td> </tr> </tbody> </table>		Characteristics		Change from the value before test	Class 1	C0G	Capacitance drift within ± 7.5% or ± 0.75pF, whichever larger.	Class 2	X7R X8R	± 15 %
			Characteristics		Change from the value before test								
			Class 1		C0G	Capacitance drift within ± 7.5% or ± 0.75pF, whichever larger.							
		Class 2	X7R X8R		± 15 %								
Q (Class 1)	<table border="1"> <thead> <tr> <th>Capacitance</th> <th>Q</th> </tr> </thead> <tbody> <tr> <td>30pF and over</td> <td>350 and over</td> </tr> <tr> <td>10pF and over to under 30pF</td> <td>275+5/2×C min.</td> </tr> <tr> <td>Under 10pF</td> <td>200+10×C min.</td> </tr> </tbody> </table> <p style="text-align: center;">C : Rated capacitance (pF)</p>	Capacitance	Q	30pF and over	350 and over	10pF and over to under 30pF	275+5/2×C min.	Under 10pF	200+10×C min.				
	Capacitance	Q											
30pF and over	350 and over												
10pF and over to under 30pF	275+5/2×C min.												
Under 10pF	200+10×C min.												
D.F. (Class 2)	Characteristics X7R: 200% of initial spec. max. X8R: 200% of initial spec. max.												
Insulation Resistance	1,000MΩ or 50MΩ·μF min. (As for the capacitors of rated voltage 16V DC and the item below, 1,000 MΩ or 10MΩ·μF min.,) whichever smaller.												

\*As for the initial measurement of capacitors (Class 2) on number 8, 12, 13 and 14, leave capacitors at 150 –10, 0°C for 1 hour and measure the value after leaving capacitor for 24±2h in ambient conditions.



## 9. INSIDE STRUCTURE AND MATERIAL

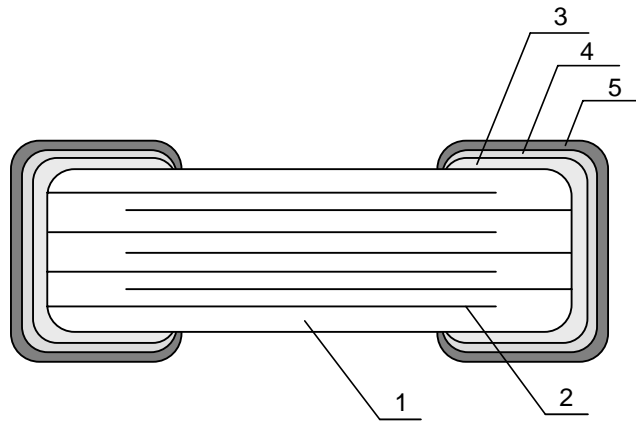

No.	NAME	MATERIAL	
		Class 1	Class 2
1	Dielectric	CaZrO <sub>3</sub>	BaTiO <sub>3</sub>
2	Electrode	Nickel (Ni)	
3	Termination	Copper (Cu)	
4		Nickel (Ni)	
5		Tin (Sn)	

## 10. RECOMMENDATION

As for CGA6 (CC1210) types, It is recommended to provide a slit (about 1mm wide) in the board under the components to improve washing flux. Please make sure to remove all cleaning solvents.

## 11. SOLDERING CONDITION

For CGA3 and CGA5 case sizes, TDK recommends reflow or wave soldering. Smaller case sizes (CGA2) and larger case sizes, (CGA6), should use reflow solder only. See "Caution" Section No. 5 for details.

## 12. Caution

No.	Process	Condition														
1	Operating Condition (Storage, Transportation)	<p>1.1 Storage</p> <ol style="list-style-type: none"> <li>The capacitor must be stored in an ambient temperature of 5 to 40°C with a relative humidity of 20 to 70%RH. The product should be used within 6 months upon receipt.</li> <li>The capacitor must be operated and stored in an environment free of condensation and corrosive gases such as hydrogen sulphide, hydrogen sulphate, chlorine, ammonia and sulfur.</li> <li>Avoid storing in sun light and falling of dew.</li> <li>Do not use capacitor under high humidity and high/low atmospheric pressure which may compromise product reliability.</li> <li>Capacitor should be tested for solderability when stored for long periods of time.</li> </ol> <p>1.2 Handling in transportation In case of the transportation the performance of the capacitor may be deteriorated depending on the transportation condition. (Refer to JEITA RCR-2335B 9.2 "Handling in transportation")</p>														
2	Circuit design	<p>2.1 Operating temperature Operating temperature should be followed strictly within this specification</p> <ol style="list-style-type: none"> <li>Do not use capacitors above the maximum allowable operating temperature.</li> <li>Surface temperature including self heating should be below maximum operating temperature. (Due to dielectric loss, capacitors will heat itself when AC is applied. Especially at high frequencies around its SRF, the heat might be so extreme that it may damage itself or the product its mounted on. Please design the circuit so that the maximum temperature of the capacitors (including the self heating) will be below the maximum allowable operating temperature. Temperature rise at capacitor surface shall be below 20°C)</li> <li>The electrical characteristics of the capacitor will vary depending on the temperature. The capacitor should be selected and designed after taking temperature into consideration.</li> </ol> <p>2.2 Operating voltage</p> <ol style="list-style-type: none"> <li>Operating voltage across the terminals should be below the rated voltage. When AC and DC are super imposed, <math>V_{0-P}</math> must be below the rated voltage. Reference: figures 1 and 2 below. AC or pulse with overshooting, <math>V_{P-P}</math> must be below the rated voltage. Reference figures 3, 4, and 5 below. When the voltage is started/ stopped to apply to the circuit an irregular voltage may be generated for a transit period because of resonance or switching. Be sure to use the capacitor within rated voltage during these Irregular voltage periods.</li> </ol> <table border="1" style="width: 100%; border-collapse: collapse;"> <thead> <tr> <th style="width: 20%;">Voltage</th> <th style="width: 25%;">(1) DC voltage</th> <th style="width: 25%;">(2) DC+AC voltage</th> <th style="width: 30%;">(3) AC voltage</th> </tr> </thead> <tbody> <tr> <td style="text-align: center;">Positional Measurement (Rated voltage)</td> <td style="text-align: center;"> </td> <td style="text-align: center;"> </td> <td style="text-align: center;"> </td> </tr> </tbody> </table> <table border="1" style="width: 100%; border-collapse: collapse;"> <thead> <tr> <th style="width: 20%;">Voltage</th> <th style="width: 30%;">(4) Pulse voltage (A)</th> <th style="width: 50%;">(5) Pulse voltage (B)</th> </tr> </thead> <tbody> <tr> <td style="text-align: center;">Positional Measurement (Rated voltage)</td> <td style="text-align: center;"> </td> <td style="text-align: center;"> </td> </tr> </tbody> </table>	Voltage	(1) DC voltage	(2) DC+AC voltage	(3) AC voltage	Positional Measurement (Rated voltage)				Voltage	(4) Pulse voltage (A)	(5) Pulse voltage (B)	Positional Measurement (Rated voltage)		
Voltage	(1) DC voltage	(2) DC+AC voltage	(3) AC voltage													
Positional Measurement (Rated voltage)																
Voltage	(4) Pulse voltage (A)	(5) Pulse voltage (B)														
Positional Measurement (Rated voltage)																

(12. Caution, continued)

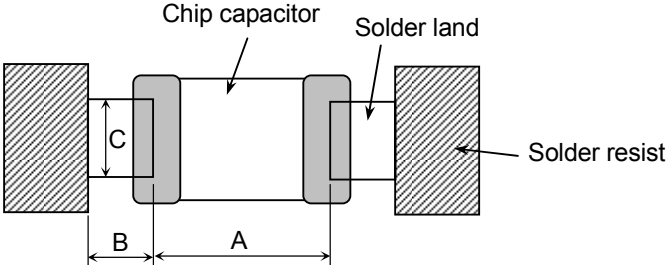
No.	Process	Condition																																												
2	Circuit design	<p>2.2 Operating Voltage (continued)</p> <p>2. Even below the rated voltage, if repetitive high AC frequency or pulsed voltage is applied, the reliability of the capacitors may be reduced.</p> <p>3. The effective capacitance will vary depending on applied DC and AC voltages. The capacitor should be selected after considering the voltage affect.</p> <p>2.3 Frequency</p> <p>When Class 2 capacitors are used in AC and/or pulsed voltages, the capacitors may self vibrate and generate audible sound (piezoelectric affect).</p>																																												
3	Designing P.C. Board	<p>The amount of solder at the terminations has a direct effect on the reliability of the capacitor.</p> <p>1. The greater the amount of solder, the higher the stress on the chip capacitor, and the more likely that it will break. When designing a P.C. board, determine the shape and size of the solder lands to have proper amount of solder on the terminations.</p> <p>2. Avoid using common solder land for multiple terminations and provide individual solder land for each termination instead.</p> <p>3. Size and recommended land dimensions provided below:</p> <div style="text-align: center;">  </div> <p style="text-align: center;">Flow soldering (mm)</p> <table border="1" style="width: 100%; border-collapse: collapse;"> <thead> <tr> <th>Type</th> <th>CGA3 [CC0603]</th> <th>CGA4 [CC0805]</th> <th>CGA5 [CC1206]</th> </tr> </thead> <tbody> <tr> <td>A</td> <td>0.7 - 1.0</td> <td>1.0 - 1.3</td> <td>2.1 - 2.5</td> </tr> <tr> <td>B</td> <td>0.8 - 1.0</td> <td>1.0 - 1.2</td> <td>1.1 - 1.3</td> </tr> <tr> <td>C</td> <td>0.6 - 0.8</td> <td>0.8 - 1.1</td> <td>1.0 - 1.3</td> </tr> </tbody> </table> <p style="text-align: center;">Reflow soldering (mm)</p> <table border="1" style="width: 100%; border-collapse: collapse;"> <thead> <tr> <th>Type</th> <th>CGA2 [CC0402]</th> <th>CGA3 [CC0603]</th> <th>CGA4 [CC0805]</th> <th>CGA5 [CC1206]</th> </tr> </thead> <tbody> <tr> <td>A</td> <td>0.3 - 0.5</td> <td>0.6 - 0.8</td> <td>0.9 - 1.2</td> <td>2.0 - 2.4</td> </tr> <tr> <td>B</td> <td>0.35 - 0.45</td> <td>0.6 - 0.8</td> <td>0.7 - 0.9</td> <td>1.0 - 1.2</td> </tr> <tr> <td>C</td> <td>0.4 - 0.6</td> <td>0.6 - 0.8</td> <td>0.9 - 1.2</td> <td>1.1 - 1.6</td> </tr> </tbody> </table> <table border="1" style="width: 100%; border-collapse: collapse; margin-top: 10px;"> <thead> <tr> <th>Type</th> <th>CGA6 [CC1210]</th> </tr> </thead> <tbody> <tr> <td>A</td> <td>2.0 - 2.4</td> </tr> <tr> <td>B</td> <td>1.0 - 1.2</td> </tr> <tr> <td>C</td> <td>1.9 - 2.5</td> </tr> </tbody> </table>	Type	CGA3 [CC0603]	CGA4 [CC0805]	CGA5 [CC1206]	A	0.7 - 1.0	1.0 - 1.3	2.1 - 2.5	B	0.8 - 1.0	1.0 - 1.2	1.1 - 1.3	C	0.6 - 0.8	0.8 - 1.1	1.0 - 1.3	Type	CGA2 [CC0402]	CGA3 [CC0603]	CGA4 [CC0805]	CGA5 [CC1206]	A	0.3 - 0.5	0.6 - 0.8	0.9 - 1.2	2.0 - 2.4	B	0.35 - 0.45	0.6 - 0.8	0.7 - 0.9	1.0 - 1.2	C	0.4 - 0.6	0.6 - 0.8	0.9 - 1.2	1.1 - 1.6	Type	CGA6 [CC1210]	A	2.0 - 2.4	B	1.0 - 1.2	C	1.9 - 2.5
Type	CGA3 [CC0603]	CGA4 [CC0805]	CGA5 [CC1206]																																											
A	0.7 - 1.0	1.0 - 1.3	2.1 - 2.5																																											
B	0.8 - 1.0	1.0 - 1.2	1.1 - 1.3																																											
C	0.6 - 0.8	0.8 - 1.1	1.0 - 1.3																																											
Type	CGA2 [CC0402]	CGA3 [CC0603]	CGA4 [CC0805]	CGA5 [CC1206]																																										
A	0.3 - 0.5	0.6 - 0.8	0.9 - 1.2	2.0 - 2.4																																										
B	0.35 - 0.45	0.6 - 0.8	0.7 - 0.9	1.0 - 1.2																																										
C	0.4 - 0.6	0.6 - 0.8	0.9 - 1.2	1.1 - 1.6																																										
Type	CGA6 [CC1210]																																													
A	2.0 - 2.4																																													
B	1.0 - 1.2																																													
C	1.9 - 2.5																																													

(12. Caution, continued)

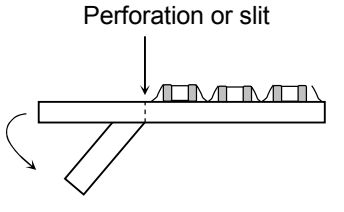
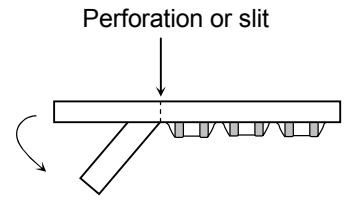
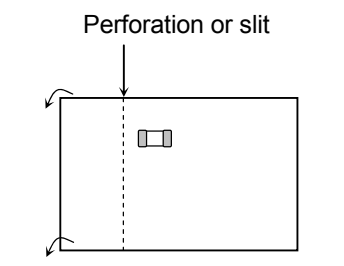
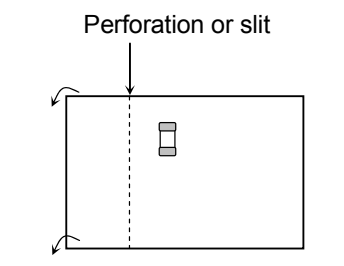
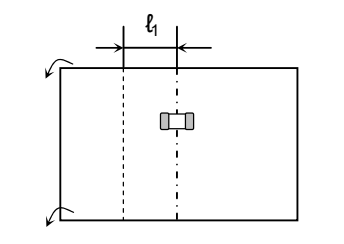
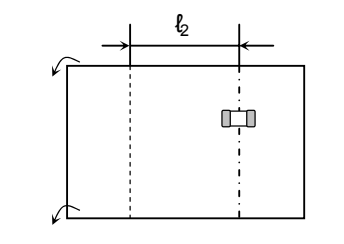
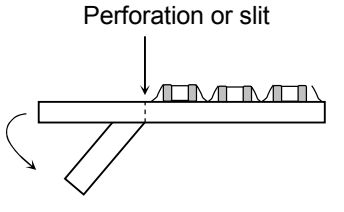
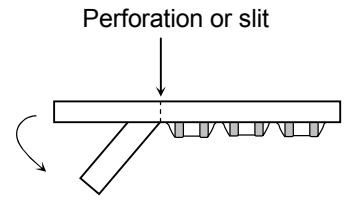
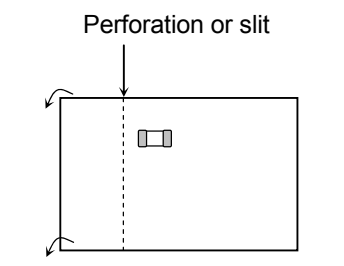
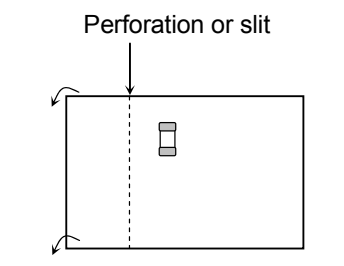
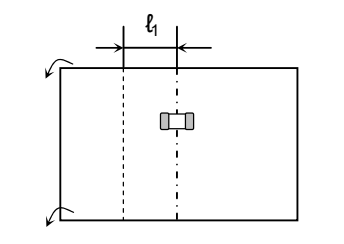
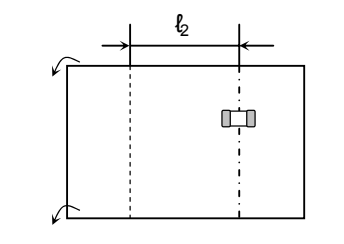
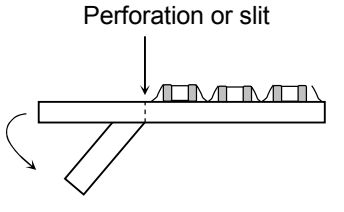
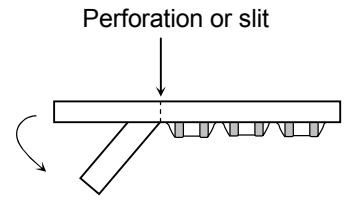
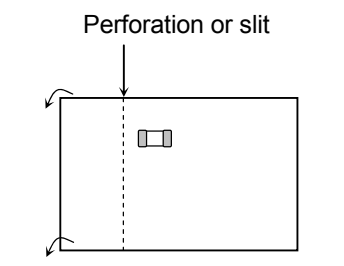
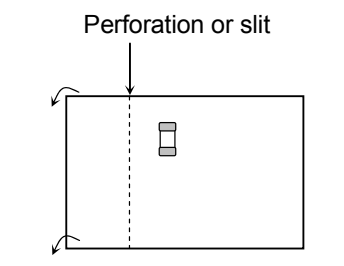
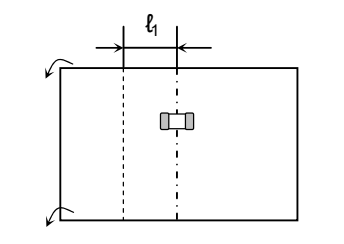
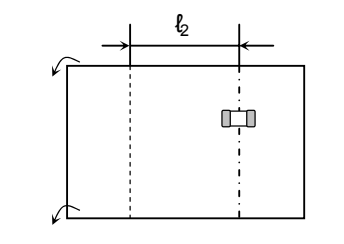
No.	Process	Condition												
3	Designing P.C. Board	<p>4. Recommended chip capacitor layout is provided below:</p> <table border="1"> <thead> <tr> <th data-bbox="508 302 683 380"></th> <th data-bbox="683 302 1040 380">Disadvantage against bending stress</th> <th data-bbox="1040 302 1398 380">Advantage against bending stress</th> </tr> </thead> <tbody> <tr> <td data-bbox="508 380 683 768">Mounting face</td> <td data-bbox="683 380 1040 768"> <p>Perforation or slit</p>  <p>Break P.C. board with mounted side up.</p> </td> <td data-bbox="1040 380 1398 768"> <p>Perforation or slit</p>  <p>Break P.C. board with mounted side down.</p> </td> </tr> <tr> <td data-bbox="508 768 683 1188">Chip arrangement (Direction)</td> <td data-bbox="683 768 1040 1188"> <p>Mount perpendicularly to perforation or slit</p> <p>Perforation or slit</p>  </td> <td data-bbox="1040 768 1398 1188"> <p>Mount in parallel with perforation or slit</p> <p>Perforation or slit</p>  </td> </tr> <tr> <td data-bbox="508 1188 683 1640">Distance from slit</td> <td data-bbox="683 1188 1040 1640"> <p>Closer to slit is higher stress</p>  <p><math>(l_1 &lt; l_2)</math></p> </td> <td data-bbox="1040 1188 1398 1640"> <p>Away from slit is less stress</p>  <p><math>(l_1 &lt; l_2)</math></p> </td> </tr> </tbody> </table>		Disadvantage against bending stress	Advantage against bending stress	Mounting face	<p>Perforation or slit</p>  <p>Break P.C. board with mounted side up.</p>	<p>Perforation or slit</p>  <p>Break P.C. board with mounted side down.</p>	Chip arrangement (Direction)	<p>Mount perpendicularly to perforation or slit</p> <p>Perforation or slit</p> 	<p>Mount in parallel with perforation or slit</p> <p>Perforation or slit</p> 	Distance from slit	<p>Closer to slit is higher stress</p>  <p><math>(l_1 &lt; l_2)</math></p>	<p>Away from slit is less stress</p>  <p><math>(l_1 &lt; l_2)</math></p>
	Disadvantage against bending stress	Advantage against bending stress												
Mounting face	<p>Perforation or slit</p>  <p>Break P.C. board with mounted side up.</p>	<p>Perforation or slit</p>  <p>Break P.C. board with mounted side down.</p>												
Chip arrangement (Direction)	<p>Mount perpendicularly to perforation or slit</p> <p>Perforation or slit</p> 	<p>Mount in parallel with perforation or slit</p> <p>Perforation or slit</p> 												
Distance from slit	<p>Closer to slit is higher stress</p>  <p><math>(l_1 &lt; l_2)</math></p>	<p>Away from slit is less stress</p>  <p><math>(l_1 &lt; l_2)</math></p>												

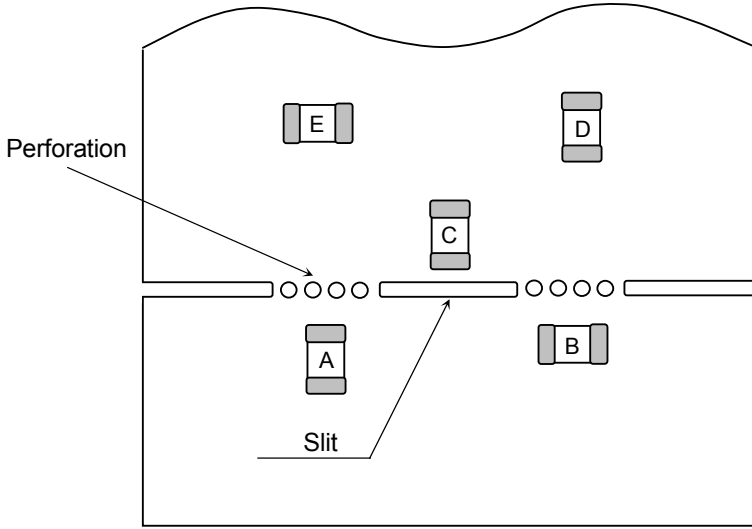
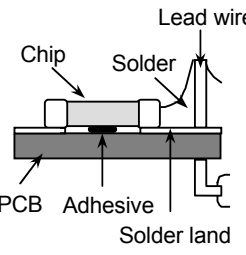
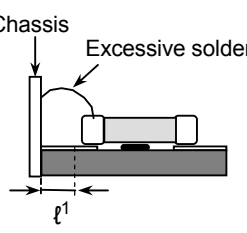
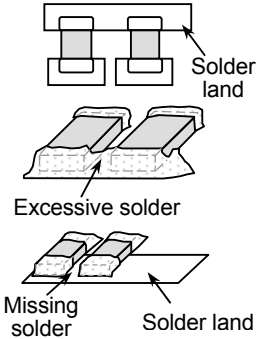
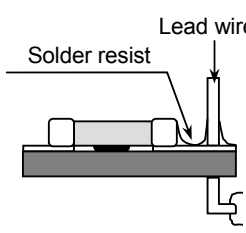
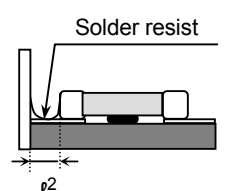
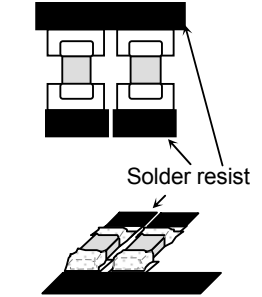
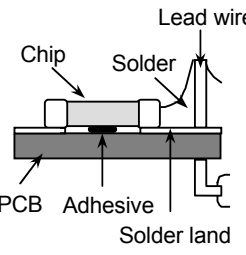
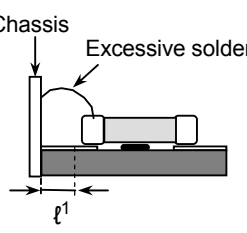
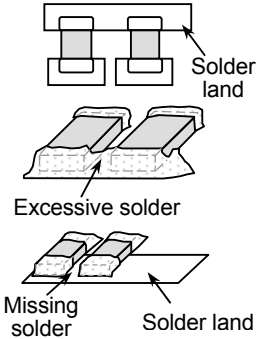
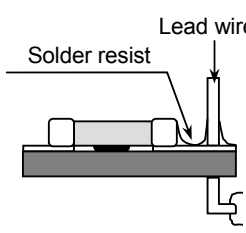
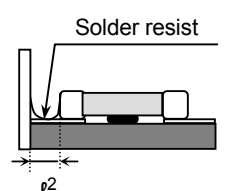
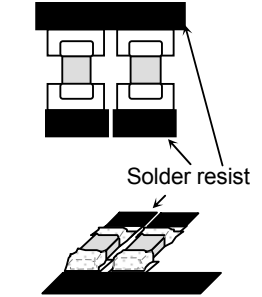
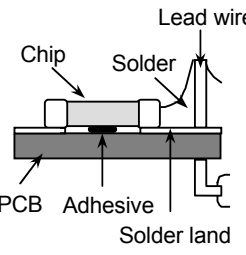
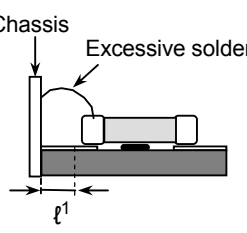
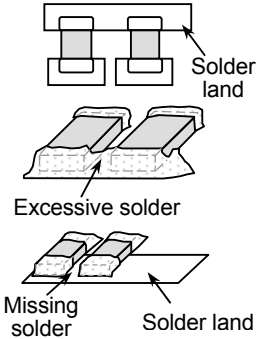
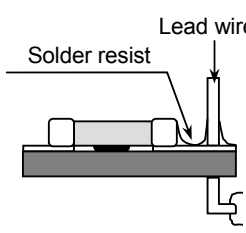
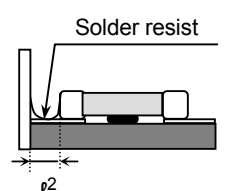
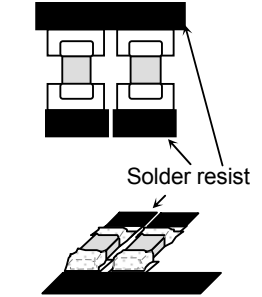
No.	Process	Condition												
3	Designing P.C. Board	<p>5. Mechanical stress varies according to location of chip capacitor on the P.C. board.</p>  <p>The relative stress applied to these in capacitors during depaneling is in the following order.</p> <p style="text-align: center;"><math>A &gt; B = C &gt; D &gt; E</math></p> <p>6. Layout recommendation</p> <table border="1" data-bbox="415 997 1442 1858"> <thead> <tr> <th data-bbox="415 997 570 1108">Example</th> <th data-bbox="578 997 854 1108">Use of common solder land</th> <th data-bbox="862 997 1138 1108">Soldering with chassis</th> <th data-bbox="1146 997 1442 1108">Use of common solder land with other SMD</th> </tr> </thead> <tbody> <tr> <td data-bbox="415 1119 570 1465">Need to avoid</td> <td data-bbox="578 1119 854 1465">  </td> <td data-bbox="862 1119 1138 1465">  </td> <td data-bbox="1146 1119 1442 1465">  </td> </tr> <tr> <td data-bbox="415 1476 570 1858">Recommendation</td> <td data-bbox="578 1476 854 1858">  </td> <td data-bbox="862 1476 1138 1858">  <p style="text-align: center;"><math>l^2 &gt; l^1</math></p> </td> <td data-bbox="1146 1476 1442 1858">  </td> </tr> </tbody> </table>	Example	Use of common solder land	Soldering with chassis	Use of common solder land with other SMD	Need to avoid				Recommendation		 <p style="text-align: center;"><math>l^2 &gt; l^1</math></p>	
Example	Use of common solder land	Soldering with chassis	Use of common solder land with other SMD											
Need to avoid														
Recommendation		 <p style="text-align: center;"><math>l^2 &gt; l^1</math></p>												

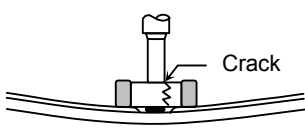
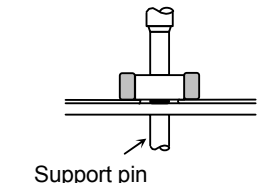
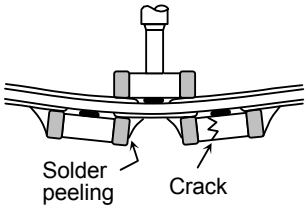
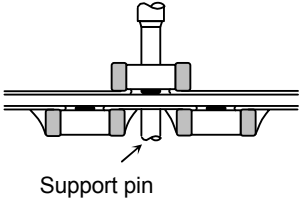
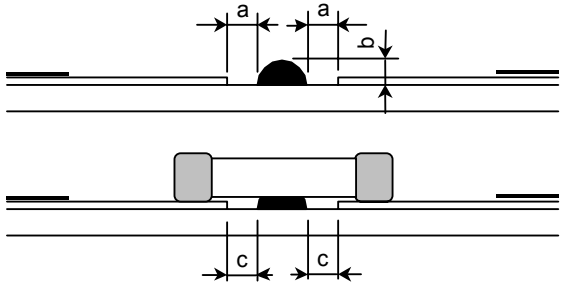
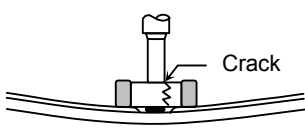
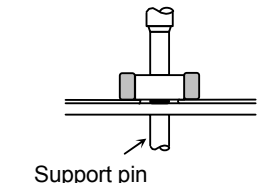
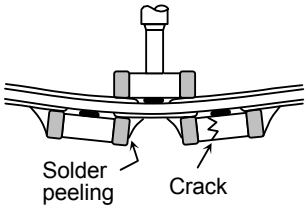
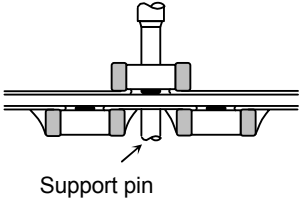
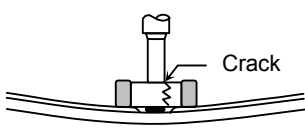
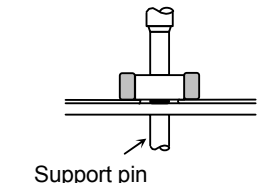
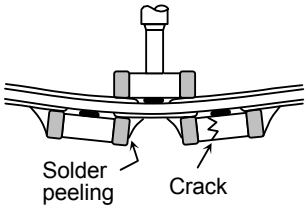
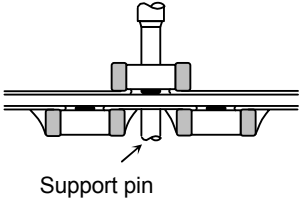

(12. Caution, continued)

No.	Process	Condition																	
4	Mounting	<p>4.1 Stress from mounting head</p> <p>If the mounting head is adjusted too low, it may induce excessive stress on the chip capacitor and result in cracking. Please take following precautions.</p> <ol style="list-style-type: none"> <li>1. Adjust the bottom dead center of the mounting head to reach the P.C. board surface but do not contact it.</li> <li>2. Adjust the mounting head pressure to be 1 to 3N of static weight.</li> <li>3. To minimize the impact energy from mounting head, it is important to provide support from the bottom side of the P.C. board. See following examples.</li> </ol> <table border="1" data-bbox="516 590 1403 1115"> <thead> <tr> <th></th> <th data-bbox="688 590 1057 638">Not recommended</th> <th data-bbox="1057 590 1403 638">Recommended</th> </tr> </thead> <tbody> <tr> <td data-bbox="516 638 688 869">Single sided mounting</td> <td data-bbox="688 638 1057 869">  </td> <td data-bbox="1057 638 1403 869">  </td> </tr> <tr> <td data-bbox="516 869 688 1115">Double-sides mounting</td> <td data-bbox="688 869 1057 1115">  </td> <td data-bbox="1057 869 1403 1115">  </td> </tr> </tbody> </table> <p>When the centering jaw is worn, mechanical impact on the capacitor may occur and damage the product. Please control the closing dimension of the centering jaw and provide sufficient preventive maintenance and/or replacement if necessary.</p> <p>4.2 Amount of adhesive</p>  <table border="1" data-bbox="683 1661 1198 1856"> <thead> <tr> <th colspan="2" data-bbox="683 1661 1198 1696">Example : CGA4 (CC0805), CGA5 (CC1206)</th> </tr> </thead> <tbody> <tr> <td data-bbox="683 1696 821 1755">a</td> <td data-bbox="821 1696 1198 1755">0.2mm min.</td> </tr> <tr> <td data-bbox="683 1755 821 1803">b</td> <td data-bbox="821 1755 1198 1803">70 - 100µm</td> </tr> <tr> <td data-bbox="683 1803 821 1856">c</td> <td data-bbox="821 1803 1198 1856">Do not touch the solder land</td> </tr> </tbody> </table>		Not recommended	Recommended	Single sided mounting			Double-sides mounting			Example : CGA4 (CC0805), CGA5 (CC1206)		a	0.2mm min.	b	70 - 100µm	c	Do not touch the solder land
	Not recommended	Recommended																	
Single sided mounting																			
Double-sides mounting																			
Example : CGA4 (CC0805), CGA5 (CC1206)																			
a	0.2mm min.																		
b	70 - 100µm																		
c	Do not touch the solder land																		

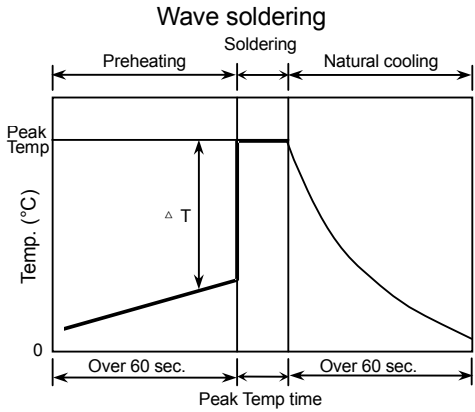
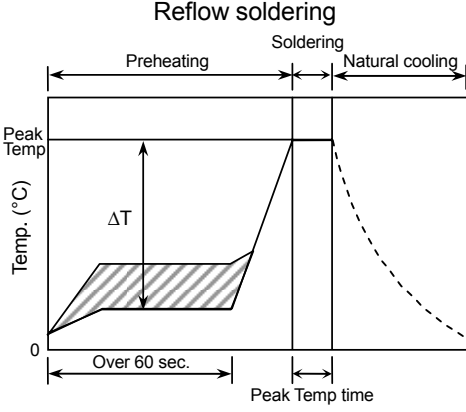
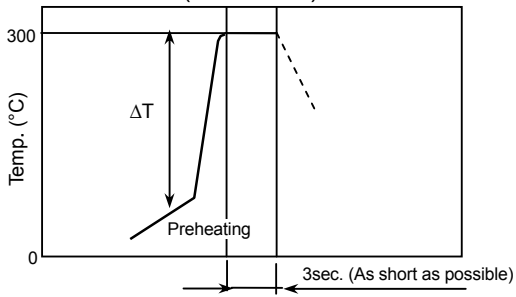
(12. Caution, continued)

No.	Process	Condition																			
5	Soldering (continued)	<p>5.1 Flux selection</p> <p>Although highly-activated flux gives better solderability, substances which increase activity may also degrade the insulation of the chip capacitor. To avoid such degradation, the following is recommended:</p> <ol style="list-style-type: none"> <li>1. Use a mildly activated rosin flux (less than 0.1wt% chlorine).</li> <li>2. Excessive flux must be avoided. Please provide proper amount of flux.</li> <li>3. When water-soluble flux is used, sufficient washing is necessary.</li> </ol> <p>5.2 Recommended soldering profile by various methods</p> <div style="display: flex; justify-content: space-around;"> <div style="text-align: center;"> <p><b>Wave soldering</b></p>  </div> <div style="text-align: center;"> <p><b>Reflow soldering</b></p>  </div> </div> <div style="text-align: center; margin-top: 20px;"> <p><b>Manual soldering (Solder iron)</b></p>  </div> <div style="margin-top: 20px;"> <p><b>APPLICATION</b></p> <p>As for CGA3 (CC0603), CGA4 (CC0805) and CGA5 (CC1206), applied to wave soldering and reflow soldering.</p> <p>As for CGA2 (CC0402), CGA6 (CC1210), applied only to reflow soldering.</p> </div> <p>5.3 Recommended soldering and duration</p> <table border="1" style="width: 100%; border-collapse: collapse;"> <thead> <tr> <th rowspan="2" style="text-align: center;">Temp./Duration</th> <th colspan="2" style="text-align: center;">Wave soldering</th> <th colspan="2" style="text-align: center;">Reflow soldering</th> </tr> <tr> <th style="text-align: center;">Peak temp(°C)</th> <th style="text-align: center;">Duration(sec.)</th> <th style="text-align: center;">Peak temp(°C)</th> <th style="text-align: center;">Duration(sec.)</th> </tr> </thead> <tbody> <tr> <td style="text-align: center;">Pb-Sn Solder</td> <td style="text-align: center;">250 max.</td> <td style="text-align: center;">3 max.</td> <td style="text-align: center;">230 max.</td> <td style="text-align: center;">20 max.</td> </tr> <tr> <td style="text-align: center;">Lead Free Solder</td> <td style="text-align: center;">260 max.</td> <td style="text-align: center;">5 max.</td> <td style="text-align: center;">260 max.</td> <td style="text-align: center;">10 max.</td> </tr> </tbody> </table> <p>Recommended solder compositions</p> <p>Sn-37Pb (Pb-Sn solder)</p> <p>Sn-3.0Ag-0.5Cu (Lead Free Solder)</p>	Temp./Duration	Wave soldering		Reflow soldering		Peak temp(°C)	Duration(sec.)	Peak temp(°C)	Duration(sec.)	Pb-Sn Solder	250 max.	3 max.	230 max.	20 max.	Lead Free Solder	260 max.	5 max.	260 max.	10 max.
Temp./Duration	Wave soldering			Reflow soldering																	
	Peak temp(°C)	Duration(sec.)	Peak temp(°C)	Duration(sec.)																	
Pb-Sn Solder	250 max.	3 max.	230 max.	20 max.																	
Lead Free Solder	260 max.	5 max.	260 max.	10 max.																	

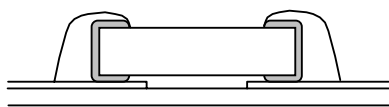
(12. Caution, continued)

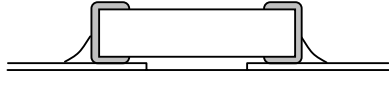
No.	Process	Condition																
5	Soldering (continued)	<p data-bbox="488 289 786 317">5.4 Avoiding thermal shock</p> <p data-bbox="488 325 760 352">1. Preheating condition</p> <table border="1" data-bbox="581 359 1398 642"> <thead> <tr> <th data-bbox="581 359 792 394">Soldering</th> <th data-bbox="792 359 1203 394">Type</th> <th data-bbox="1203 359 1398 394">Temp. (°C)</th> </tr> </thead> <tbody> <tr> <td data-bbox="581 394 792 457">Wave soldering</td> <td data-bbox="792 394 1203 457">CGA3(CC0603), CGA4(CC0805), CGA5(CC1206)</td> <td data-bbox="1203 394 1398 457"><math>\Delta T \leq 150</math></td> </tr> <tr> <td data-bbox="581 457 792 548" rowspan="2">Reflow soldering</td> <td data-bbox="792 457 1203 520">CGA2(CC0402), CGA3(CC0603), CGA4(CC0805), CGA5(CC1206)</td> <td data-bbox="1203 457 1398 520"><math>\Delta T \leq 150</math></td> </tr> <tr> <td data-bbox="792 520 1203 548">CGA6(CC1210)</td> <td data-bbox="1203 520 1398 548"><math>\Delta T \leq 130</math></td> </tr> <tr> <td data-bbox="581 548 792 611" rowspan="2">Manual soldering</td> <td data-bbox="792 548 1203 611">CGA2(CC0402), CGA3(CC0603), CGA4(CC0805), CGA5(CC1206)</td> <td data-bbox="1203 548 1398 611"><math>\Delta T \leq 150</math></td> </tr> <tr> <td data-bbox="792 611 1203 642">CGA6(CC1210)</td> <td data-bbox="1203 611 1398 642"><math>\Delta T \leq 130</math></td> </tr> </tbody> </table> <p data-bbox="488 695 727 722">2. Cooling condition</p> <p data-bbox="532 730 1443 800">Natural cooling using air is recommended. If the chips are dipped into a solvent for cleaning, the temperature difference (<math>\Delta T</math>) must be less than 100°C.</p> <p data-bbox="488 846 719 873">5.5 Amount of solder</p> <p data-bbox="532 882 1369 989">Excessive solder will induce higher tensile force on the chip capacitor during temperature changes and may result in chip cracking. Insufficient solder may detach the capacitor from the P.C. board.</p> <div data-bbox="540 1024 1377 1129"> <p data-bbox="540 1024 657 1087">Excessive solder</p>  <p data-bbox="1122 1024 1377 1108">Higher tensile force on the chip capacitor may cause cracking.</p> </div> <div data-bbox="540 1178 1256 1283"> <p data-bbox="540 1192 651 1220">Adequate</p>  <p data-bbox="1073 1178 1256 1234">Maximum amount Minimum amount</p> </div> <div data-bbox="540 1346 1385 1493"> <p data-bbox="540 1360 667 1423">Insufficient solder</p>  <p data-bbox="1122 1346 1385 1493">Small solder fillet may cause contact failure or not hold the chip capacitor come to the P.C. board.</p> </div> <p data-bbox="488 1528 829 1556">5.6 Solder repair by solder iron</p> <p data-bbox="488 1564 889 1591">1. Selection of the soldering iron tip</p> <p data-bbox="540 1600 1406 1682">Tip temperature of solder iron varies by its type, P.C. board material and solder land size. Higher temperatures may provide quicker the operation; however, heat shock may cause a crack in the chip capacitors.</p> <p data-bbox="540 1682 1406 1766">Please make sure the tip temperature before soldering and keep the temp and time in accordance with following recommended condition. (Please preheat the chip capacitors with the condition in 5.4 to avoid the thermal shock.)</p>	Soldering	Type	Temp. (°C)	Wave soldering	CGA3(CC0603), CGA4(CC0805), CGA5(CC1206)	$\Delta T \leq 150$	Reflow soldering	CGA2(CC0402), CGA3(CC0603), CGA4(CC0805), CGA5(CC1206)	$\Delta T \leq 150$	CGA6(CC1210)	$\Delta T \leq 130$	Manual soldering	CGA2(CC0402), CGA3(CC0603), CGA4(CC0805), CGA5(CC1206)	$\Delta T \leq 150$	CGA6(CC1210)	$\Delta T \leq 130$
Soldering	Type	Temp. (°C)																
Wave soldering	CGA3(CC0603), CGA4(CC0805), CGA5(CC1206)	$\Delta T \leq 150$																
Reflow soldering	CGA2(CC0402), CGA3(CC0603), CGA4(CC0805), CGA5(CC1206)	$\Delta T \leq 150$																
	CGA6(CC1210)	$\Delta T \leq 130$																
Manual soldering	CGA2(CC0402), CGA3(CC0603), CGA4(CC0805), CGA5(CC1206)	$\Delta T \leq 150$																
	CGA6(CC1210)	$\Delta T \leq 130$																

(12. Caution, continued)

No.	Process	Condition								
5	Soldering (continued)	<p data-bbox="553 222 1365 254">Recommended solder iron condition (Pb-Sn Solder and Lead Free Solder)</p> <table border="1" data-bbox="583 254 1362 369"><thead><tr><th data-bbox="583 254 779 306">Temp. (°C)</th><th data-bbox="779 254 974 306">Duration (sec.)</th><th data-bbox="974 254 1169 306">Wattage (W)</th><th data-bbox="1169 254 1362 306">Shape (mm)</th></tr></thead><tbody><tr><td data-bbox="583 306 779 369">300 max.</td><td data-bbox="779 306 974 369">3 max.</td><td data-bbox="974 306 1169 369">20 max.</td><td data-bbox="1169 306 1362 369">Ø 3.0 max.</td></tr></tbody></table> <p data-bbox="500 415 1393 520">2. Direct contact of the soldering iron with ceramic dielectric of the chip capacitor may cause cracking. Do not touch the ceramic dielectric and the terminations by solder iron.</p> <p data-bbox="488 579 675 611">5.7 Sn-Zn solder</p> <p data-bbox="513 611 1146 669">Sn-Zn solder affects product reliability. Please contact TDK in advance when utilize Sn-Zn solder.</p> <p data-bbox="488 701 873 732">5.8 Countermeasure for tombstone</p> <p data-bbox="513 732 1419 884">The misalignment between the mounted positions of the capacitors and the land patterns should be minimized. The tombstone phenomenon may occur especially when the capacitors are mounted (in longitudinal direction) in the same direction of the reflow soldering. (Refer to JEITA RCR-2335B Annex A "Recommendations to prevent the tombstone phenomenon")</p>	Temp. (°C)	Duration (sec.)	Wattage (W)	Shape (mm)	300 max.	3 max.	20 max.	Ø 3.0 max.
Temp. (°C)	Duration (sec.)	Wattage (W)	Shape (mm)							
300 max.	3 max.	20 max.	Ø 3.0 max.							
6	Cleaning	<p data-bbox="500 926 1443 989">1. If an unsuitable cleaning fluid is used, flux residue or some foreign articles may stick to the chip capacitor surface and deteriorate insulation resistance.</p> <p data-bbox="500 999 1443 1062">2. If cleaning condition is not suitable, it may deteriorate the chip capacitor's insulation resistance.</p> <p data-bbox="488 1073 748 1104">2.1 Insufficient washing</p> <ol data-bbox="526 1115 1395 1293" style="list-style-type: none"><li>1. Terminal electrodes may be corroded by Halogen in the flux.</li><li>2. Halogen in the flux may adhere on the surface of capacitor, and lower the insulation resistance.</li><li>3. Water soluble flux has higher tendency to have above mentioned problems (1) and (2).</li></ol> <p data-bbox="488 1314 740 1346">2.2 Excessive washing</p> <p data-bbox="578 1356 1443 1461">When ultrasonic cleaning is used, excessively high energy output can affect the connection between the ceramic chip capacitor's body and the terminal electrode. To avoid this, the following is recommended.</p> <p data-bbox="789 1482 1005 1514">Power: 20 W/l max.</p> <p data-bbox="789 1524 1057 1556">Frequency: 40 kHz max.</p> <p data-bbox="789 1566 1118 1598">Washing time: 5 minutes max.</p> <p data-bbox="488 1619 1443 1682">2.3 If the cleaning fluid is contaminated, <b>concentration of Halogen</b> can increase, and bring the same result as insufficient cleaning.</p>								

(12. Caution, continued)

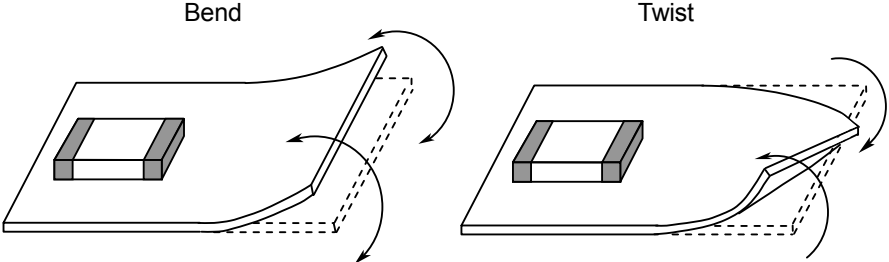
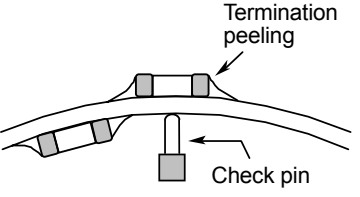
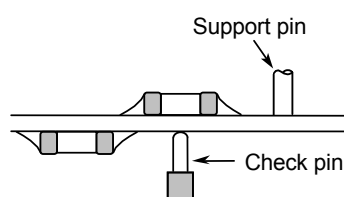
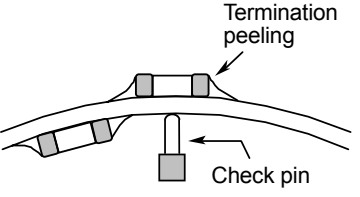
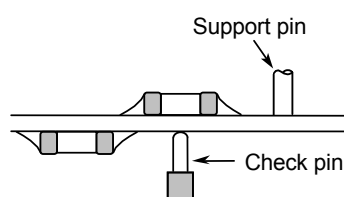
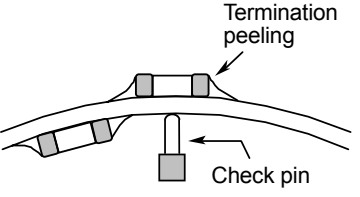
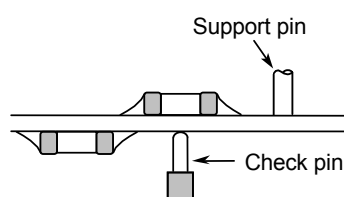
No.	Process	Condition						
7	Coating and molding of the P.C. Board	<ol style="list-style-type: none"> <li>When the P.C. board is coated, please verify the impact on the capacitor.</li> <li>Please carefully verify that there is no harmful decomposing or reaction gas emission during curing which may damage the chip capacitor.</li> <li>Please verify the curing temperature.</li> </ol>						
8	Handling after chip mounted	<ol style="list-style-type: none"> <li>Please pay attention not to bend or distort the P.C. board after soldering, otherwise the chip capacitor may crack.                     <div style="text-align: center; margin: 10px 0;">  </div> </li> <li>When functional check of the P.C. board is performed, high pin pressure tends to be used for fear of loose contact. But if the pressure is excessive and bends the P.C. board, it may crack the chip capacitor or peel the termination. Please adjust the pins accordingly to ensure the P.C. board is not flexed.                     <table border="1" style="width: 100%; margin-top: 10px;"> <thead> <tr> <th data-bbox="526 1041 656 1094">Item</th> <th data-bbox="656 1041 1045 1094">Not recommended</th> <th data-bbox="1045 1041 1419 1094">Recommended</th> </tr> </thead> <tbody> <tr> <td data-bbox="526 1094 656 1373" style="text-align: center; vertical-align: middle;">Board bending</td> <td data-bbox="656 1094 1045 1373" style="text-align: center;">  </td> <td data-bbox="1045 1094 1419 1373" style="text-align: center;">  </td> </tr> </tbody> </table> </li> </ol>	Item	Not recommended	Recommended	Board bending		
Item	Not recommended	Recommended						
Board bending								

(12. Caution, continued)

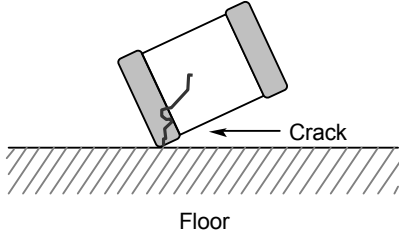
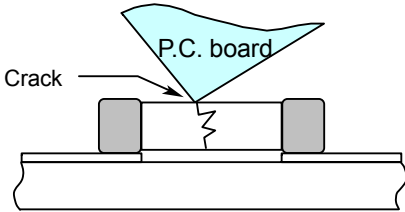
No.	Process	Condition
9	Handling of loose chip capacitors	<p>1. The chip capacitor may crack if dropped, especially large case sizes. Please handle with care and so not use if dropped.</p>  <p>Floor</p> <p>Crack</p> <p>2. When stacking the P.C. board for storage or handling after soldering, the corner of the P.C. board may hit the chip capacitor a neighboring board and cause a crack.</p>  <p>P.C. board</p> <p>Crack</p>
10	Capacitance aging	Class 2 capacitors have an aging characteristic, which is a decrease in capacitance over time due to crystalline changes that occur in ferroelectric ceramics. Careful consideration should be done in case of a time constant circuit.
11	Estimated life and estimated failure rate of capacitors	The estimated life and (failure rate) depend on the temperature and the voltage applied. This can be calculated by the equation described in JEITA RCR-2335B Annex 6 "Calculation of the estimated lifetime and the estimated failure rate." The risk can be decreased by reducing the temperature and the voltage but the failure rate can not be guaranteed.
12	Others	<p>The products listed on this specification sheet are intended for use in general electronic equipment (AV equipment, telecommunications equipment, home appliances, amusement equipment, computer equipment, personal equipment, office equipment, measurement equipment, industrial robots) and automotive application under a normal operation and use condition.</p> <p>The products are not designed or warranted to meet the requirements of the applications listed below, whose performance and/or quality require a more stringent level of safety or reliability, or whose failure, malfunction or trouble could cause serious damage to society, person or property. Please understand that TDK is not responsible for any damage or liability caused by use of this product in any of the applications below or for any other use exceeding the range or conditions set forth in this specification sheet:</p> <p>Aerospace/Aviation equipment. Transportation equipment (electric trains, ships, etc. except automotive application) Medical equipment. Power-generation control equipment. Atomic energy-related equipment. Seabed equipment. Transportation control equipment. Public information-processing equipment. Military equipment. Electric heating apparatus, burning equipment. Disaster prevention/crime prevention equipment. Safety equipment. Other applications that are not considered general-purpose applications.</p> <p>When using this product in general-purpose applications, you are kindly requested to take into consideration securing protection circuit/equipment or providing backup circuits, etc., to ensure higher safety.</p>

### 13. PACKAGING LABEL

Packaging shall be done to protect the components from the damage during transportation and storing, and a label which has the following information shall be attached.

- 1) Inspection No.
- 2) TDK P/N
- 3) Customer's P/N
- 4) Quantity

\*Composition of Inspection No.

Example     M 0 A - 00 - 000  
                  (a) (b) (c)        (d)        (e)

- a) Line code
- b) Last digit of the year
- c) Month and A for January and B for February and so on. (Skip I)
- d) Inspection Date of the month.
- e) Serial No. of the day

### 14. BULK PACKAGING QUANTITY

Total number of components in a plastic bag for bulk packaging: 1,000pcs.  
As for CGA2 types, not available for bulk packaging.

# 15. TAPE PACKAGING SPECIFICATION

## 1. CONSTRUCTION AND DIMENSION OF TAPING

### 1. Dimensions of carrier tape

Dimensions of paper tape shall be according to Appendix 3, 4.

Dimensions of plastic tape shall be according to Appendix 5.

### 2. Bulk part and leader of taping

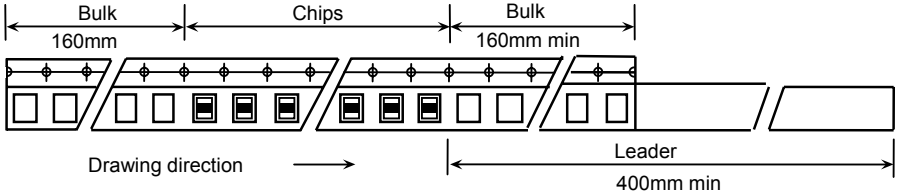

### 3. Dimensions of reel

Dimensions of Ø178 reel shall be according to Appendix 6, 7.

Dimensions of Ø330 reel shall be according to Appendix 8, 9.

### 4. Structure of taping

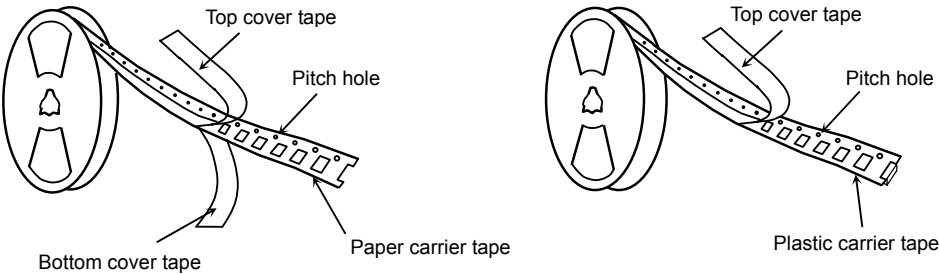

## 2. CHIP QUANTITY

Type	Thickness of chip	Taping Material	Chip quantity (pcs.)	
			Ø 178mm reel	Ø 330mm reel
CGA2	0.50 mm	Paper	10,000	50,000
CGA3	0.80 mm	Paper	4,000	10,000
CGA4	0.60mm	Paper	4,000	20,000
	0.85 mm	Paper		10,000
	1.25 mm	Plastic	2,000	
CGA5	0.60 mm	Paper	4,000	10,000
	0.85 mm			
	1.15 mm	Plastic	2,000	8,000
	1.60 mm			
CGA6	1.25 mm	Plastic	2,000	8,000
	1.60 mm			
	2.00 mm		1,000	5,000
	2.30 mm			
	2.50 mm			

## 3. PERFORMANCE SPECIFICATIONS

### 3. 1. Peel back cover (top tape)

0.05-0.7N. (See the following figure.)

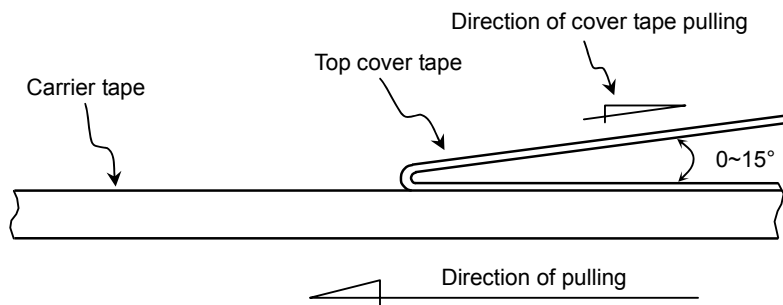

3. 2 Carrier tape shall be flexible enough to be wound around a minimum radius of 30mm with components in tape.

3. 3 The missing of components shall be less than 0.1%

3. 4 Components shall not stick to the cover tape.

3. 5 The cover tapes shall not protrude beyond the edges of the carrier tape not shall cover the sprocket holes.

## Appendix 3

### Paper Tape

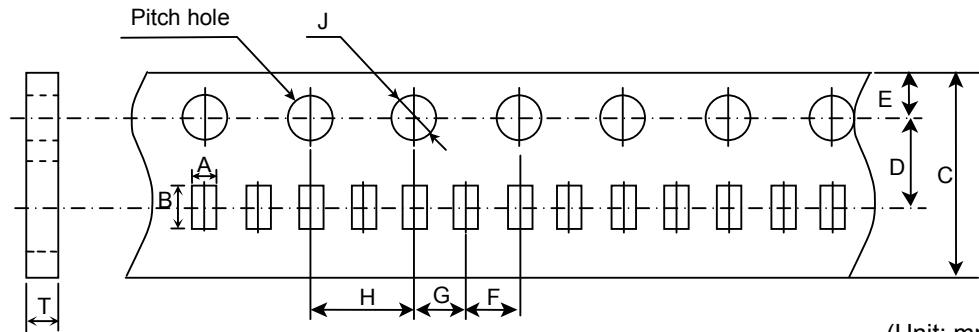

(Unit: mm)

Symbol	A	B	C	D	E	F
Type CGA2 (CC0402)	( 0.65 )	( 1.15 )	8.00 ± 0.30	3.50 ± 0.05	1.75 ± 0.10	2.00 ± 0.05

  

Symbol	G	H	J	T
Type CGA2 (CC0402)	2.00 ± 0.05	4.00 ± 0.10	∅ 1.5 <sup>+0.10</sup> <sub>0</sub>	0.60 ± 0.05

\* The values in the parentheses ( ) are for reference

## Appendix 4

### Paper Tape

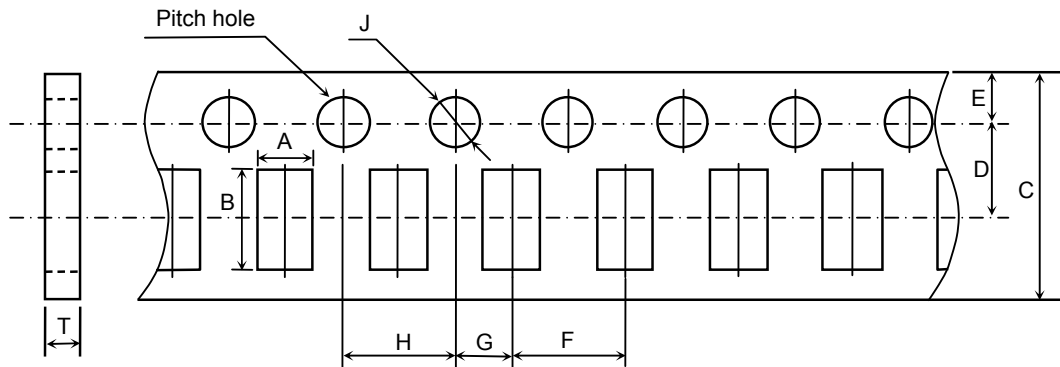

(Unit: mm)

Symbol	A	B	C	D	E	F
Type CGA3 (CC0603)	( 1.10 )	( 1.90 )	8.00 ± 0.30	3.50 ± 0.05	1.75 ± 0.10	4.00 ± 0.10
CGA4 (CC0805)	( 1.50 )	( 2.30 )				
CGA5 (CC1206)	( 1.90 )	( 3.50 )				

  

Symbol	G	H	J	T
Type CGA3 (CC0603)	2.00 ± 0.05	4.00 ± 0.10	∅ 1.5 <sup>+0.10</sup> <sub>0</sub>	1.10 max.
CGA4 (CC0805)				
CGA5 (CC1206)				

\* The values in the parentheses ( ) are for reference.

# Appendix 5

## Plastic Tape

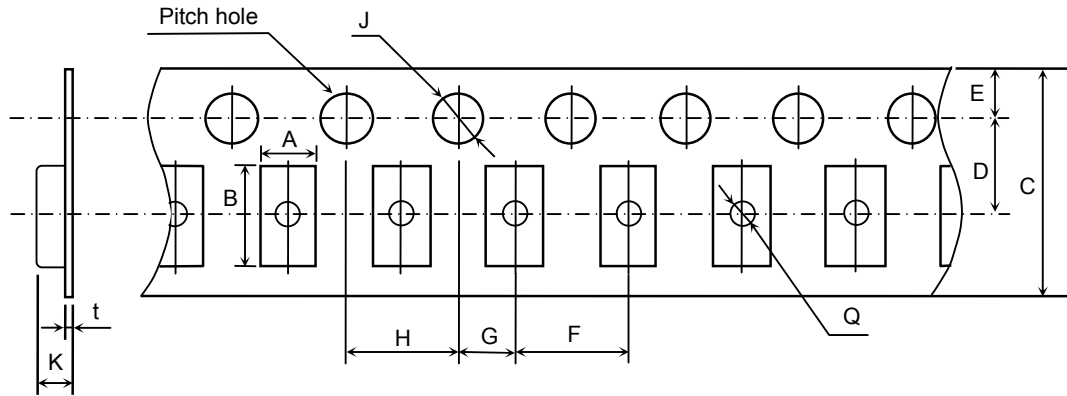

(Unit: mm)

Symbol Type	A	B	C	D	E	F
CGA4 (CC0805)	( 1.50 )	( 2.30 )	8.00 ± 0.30 [12.0 ± 0.30]	3.50 ± 0.05 [5.50 ± 0.05]	1.75 ± 0.10	4.00 ± 0.10
CGA5 (CC1206)	( 1.90 )	( 3.50 )				
CGA6 (CC1210)	( 2.90 )	( 3.60 )				

Symbol Type	G	H	J	K	t	Q
CGA4 (CC0805)	2.00 ± 0.05	4.00 ± 0.10	∅ 1.5 <sup>+0.10</sup> <sub>0</sub>	2.50 max.	0.30 max.	∅ 0.50 min.
CGA5 (CC1206)				3.20 max.	0.60 max.	
CGA6 (CC1210)						

\* The values in the parentheses ( ) are for reference.

\* As for 2.5mm thickness products, apply values in the brackets [ ].

## Appendix 6

CGA2, CGA3, CGA4, CGA5, CGA6 (As for CGA6 type, any thickness of the item except 2.5mm)

(Material: Polystyrene)

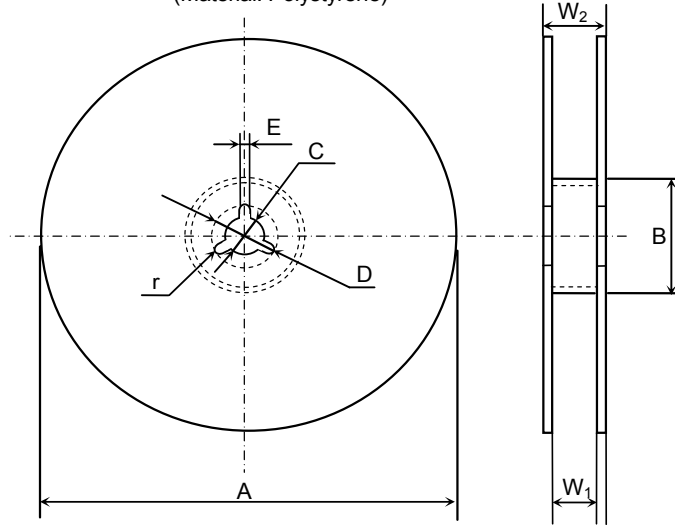

(Unit: mm)

Symbol	A	B	C	D	E	$W_1$
Dimension	$\text{Ø}178 \pm 2.0$	$\text{Ø}60 \pm 2.0$	$\text{Ø}13 \pm 0.5$	$\text{Ø}21 \pm 0.8$	$2.0 \pm 0.5$	$9.0 \pm 0.3$
Symbol	$W_2$	r				
Dimension	$13.0 \pm 1.4$	1.0				



## Appendix 8

CGA2, CGA3, CGA4, CGA5, CGA6 (As for CGA6 type, any thickness of the item except 2.5mm)

(Material: Polystyrene)

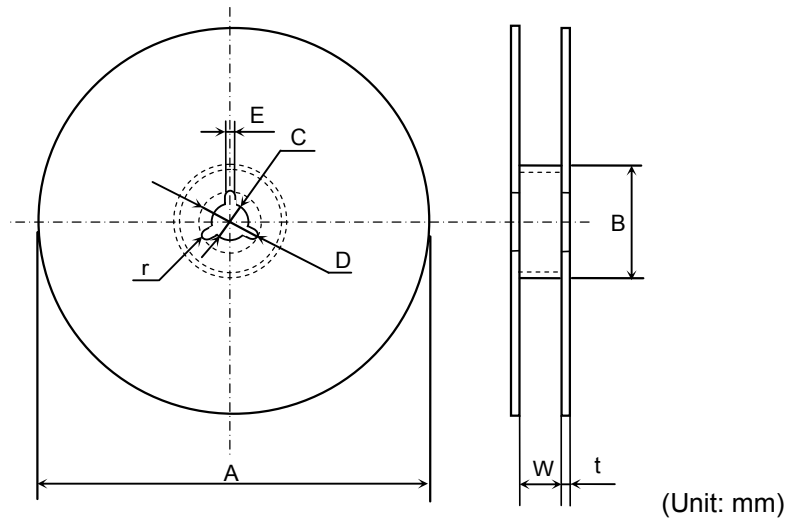

Symbol	A	B	C	D	E	W
Dimension	Ø382 max. (Nominal Ø330)	Ø50 min.	Ø13 ± 0.5	Ø21 ± 0.8	2.0 ± 0.5	10.0 ± 1.5
Symbol	t	r				
Dimension	2.0 ± 0.5	1.0				

## Appendix 9

CGA6 (Applied to 2.5mm thickness products)

(Material: Polystyrene)

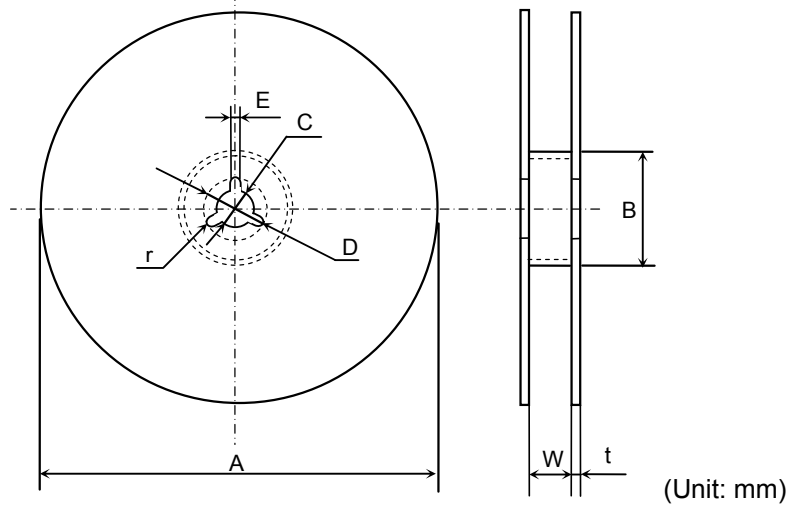

Symbol	A	B	C	D	E	W
Dimension	Ø382 max. (Nominal Ø330)	Ø50 min.	Ø13 ± 0.5	Ø21 ± 0.8	2.0 ± 0.5	14.0 ± 1.5
Symbol	t	r				
Dimension	2.0 ± 0.5	1.0				

END PAGE