



FOUP Load Port

MODEL: TAS300

TYPE: E4

Product Specifications



Table of Contents

1. -- Introduction.....	1 E190E120
2. -- Features	1 E190E120
3. -- Basic Specifications	2 E190E120
3-1 Applicable FOUPs.....	2 E190E120
3-2 Mechanical Specifications	2 E190E120
3-3 Electrical Specifications	3 E190E120
3-4 Environment.....	3 E190E120
3-5 Operation Flow	4 E190E120
3-6 Detection Function.....	5 E190E120
3-7 Indicator	6 E190E120
3-8 External View.....	7 E190E120
3-9 Dimensions.....	8 E190E120
4. -- Installation Environment	9 E190E120
4-1 Mechanical Interface	9 E190E120
4-2 Work Area	10 E190E120
4-3 Preparation.....	10 E190E120
4-4 Accessories.....	10 E190E120
5. -- Options	11 E190E120
6. -- Warnings, Cautions and Notes on Operation Safety	12 E190E120

1. Introduction

The TAS 300 is installed in a variety of semiconductor manufacturing equipment and is a standard 300mm load port that automatically opens/closes the FOUP (Front Opening Unified Pod) used in the semiconductor manufacturing process.

All semiconductor-manufacturing equipment requires low particle generation, high throughput, and reliable operation using a variety of different FOUPs. The TAS 300 provides the highest industry performance to meet the market requirements.

2. Features

- (1) Complies with the SEMI Standard.

E15.1-1104	Specifications for the load port for the 300mm machine
E57-0600E	Mechanical specifications for the kinematic coupling used for the 300mm wafer carrier positioning and support
E62-0703E	Temporary specifications for the 300mm (FIMS) front opening mechanical interface
E63-1104	Interface specifications for the mechanical standard (BOLTS-M) (between the 300mm box opener/loader and the machine)
E64-0600	Interface specifications for the SEMI E15.1 300mm docking port and cart

- (2) The movable parts (including the mapping unit) are installed below the wafer surface. TDK's best in class particle free operation is achieved by our proprietary airflow design.
- (3) An air-cushion method is used for the docking plate and the FIMS door. This means that the TAS 300 is compatible with many types of FOUPs and provides complete and reliable opening/closing.
- (4) An optional mapping unit (transmission sensor) can be installed.
- (5) The TAS 300 maintains reliable and high performance for door opening/closing repeated operations over prolonged periods with low maintenance costs.
- (6) The TAS 300 has an obstacle detection function when the FOUP is docked.
- (7) The TAS 300 has functions that detect the FOUP (when the FOUP is loaded) and detect its correct position.
- (8) The TAS 300 has a load port positioning mechanism on the BOLTS surface that shortens the load port installation/removal time.

3. Basic Specifications

3-1 Applicable FOUPs

Manufacturer	Model	Notes
Entegris	F300 · A300	A300: Manufactured by former ASYST
Shin-Etsu Polymer	300E · 300EX	
Dainichi Shoji	SF300-02	
Miraial	KT-3003	
Other		300mm FOUP complies with SEMI E47.1 and E62.

3-2 Mechanical Specifications

Dimensions/Weight			
Height		1,386mm	
Width		472mm	
Depth		493mm	From the BOLTS surface
Weight		55kg	Options: not included
Operation time			
No mapping (Standard specifications)	Open	10sec or less	FOUP insertion ~ Robot access enabled
	Close	10sec or less	Robot access enabled ~ FOUP ejection enabled
With mapping (Optional specifications)	Open	20sec or less	FOUP insertion ~ Robot access enabled
	Close	10sec or less	Robot access enabled ~ FOUP ejection enabled
Docking mechanism			
FOUP clamp	Front Retaining Feature		Air driven
FOUP door hold	Vacuum suction		
Docking stroke	70mm		
Repeatability precision	±0.1mm		
FDP ~ FIMS door distance	165.0mm		
FDP ~ frame distance	166.5mm		
Utility/Other			
Clean dry air	Pressure	0.52 ~ 0.60MPa	OD6mm air tube
	Flow	30L/min (ANR)	
Vacuum	Pressure	30 ~ 50kPa	OD6mm air tube
	Flow	10L/min (ANR)	
Exhaust			OD6mm air tube
Noise		MAX 60dB (Aeq)	

3-3 Electrical Specifications

Interface specifications *1		
Connector	Purpose	Notes
CNA1	Power	DC24V 3A
CNA2	Upper communication	RS-232C communication: D-sub 9 pin (male)
CNA3	Maintenance terminal communication	RS-232C communication: D-sub 9 pin (male)
CNA4	Parallel I/O	D-sub 25 pin (male) *2
CNA5	Operation panel I/O	TAS300 indicator control: D-sub 15 pin (female)
CNA6	CID communication	CID communication (optional): D-sub 9 pin (male/female)
CNA7	AMHS communication	AMHS communication (optional): D-sub 25 pin (male)
CNA8	CID communication	CID communication (optional): D-sub 9 pin (male/female)
Utility		
Power	DC24V \pm 5% 3A (Full-load current: 2A) Circuit breaker rating: 50A	

*1. For details, see the separate interface specifications.

*2. The D-sub 15 pin connector can be used (optional cable).

3-4 Environment

Usage environment		
Ambient temperature		5 ~ 30°C
Ambient humidity		30 ~ 80% (no condensation) 20°C : 90% or less, 40°C : 50% or less
Ambient brightness	Working area	300Lux
	Operation area	500Lux
Altitude		Sea level 1,000m or lower
Other		Install the machine in a clean room
Storage environment		
Ambient temperature		-10 ~ 55°C
Ambient humidity		30 ~ 85% (no condensation)

3-5 Operation Flow

(1) Load

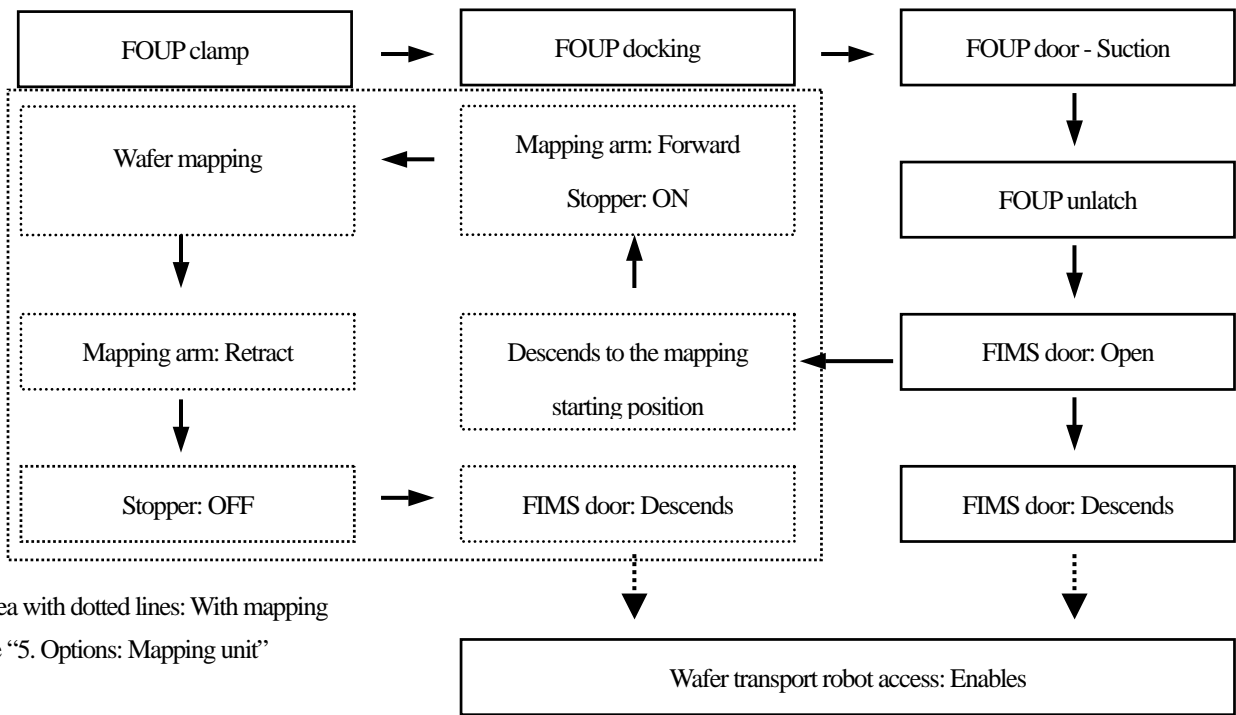

* Area with dotted lines: With mapping
See "5. Options: Mapping unit"

(2) Unload

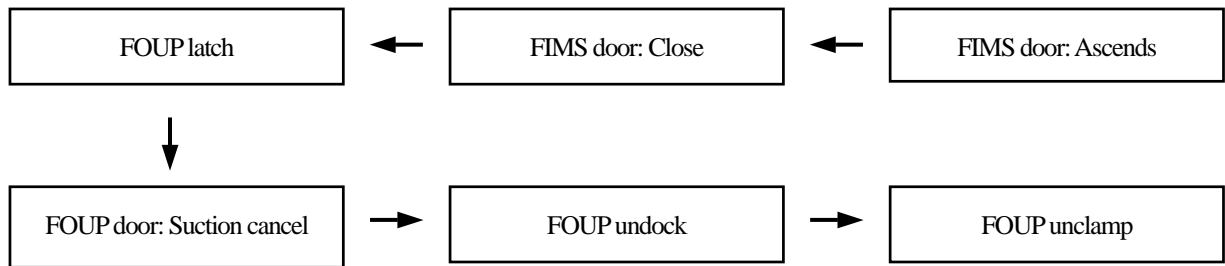

3-6 Detection Function

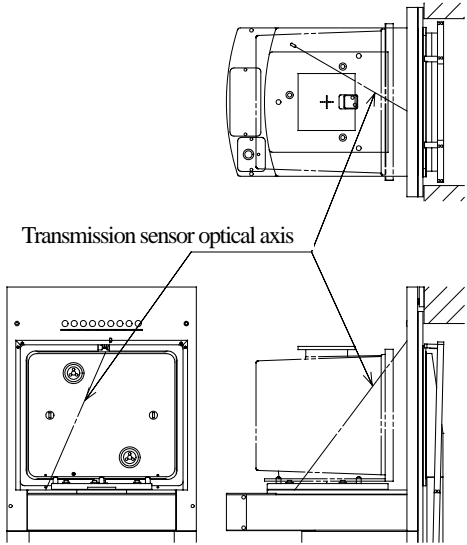
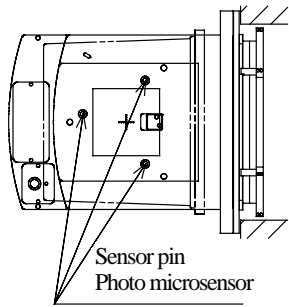
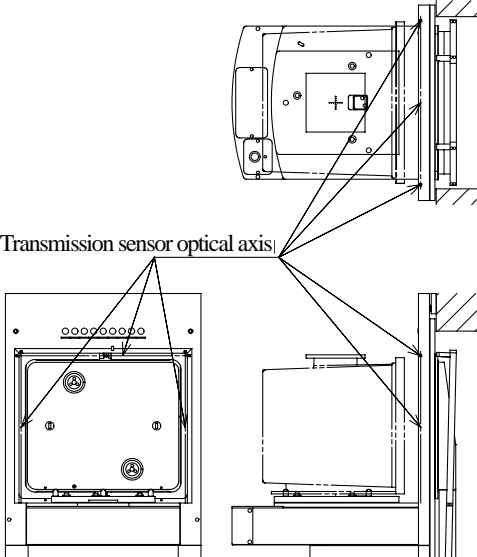
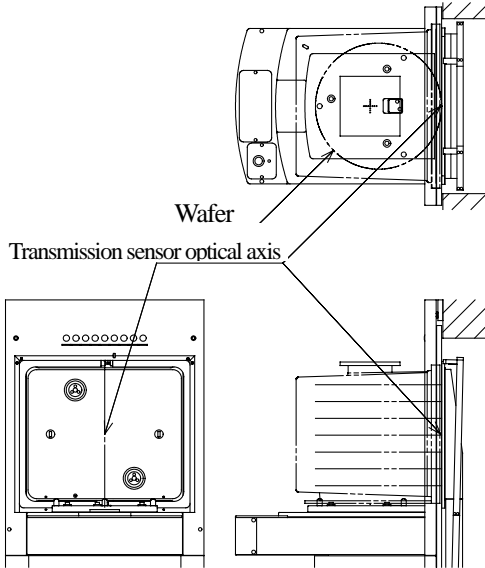
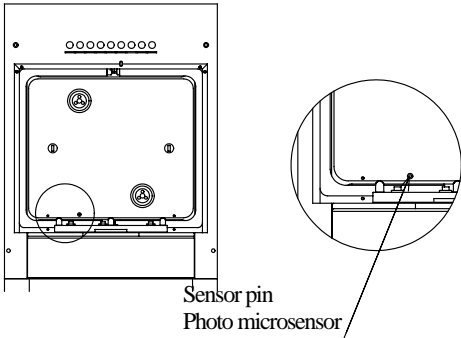
FOUP presence detection	FOUP placement check
 <p>Transmission sensor optical axis</p>	 <p>Sensor pin Photo microsensor</p>
FOUP docked: Obstacle detection	Wafer protrusion in FOUP
 <p>Transmission sensor optical axis</p>	 <p>Wafer Transmission sensor optical axis</p> <p>* Wafer protrusion (3mm) is detected from the FOUP shell seal surface. * Glass wafer function: Optional</p>
FOUP door detection	
 <p>Sensor pin Photo microsensor</p>	

3-7 Indicator

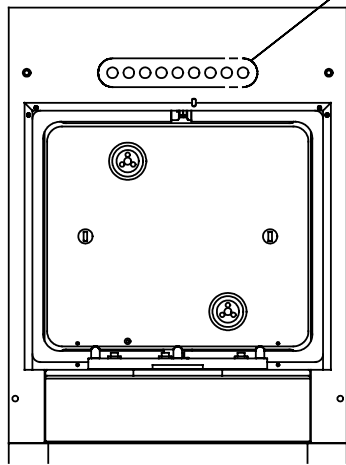
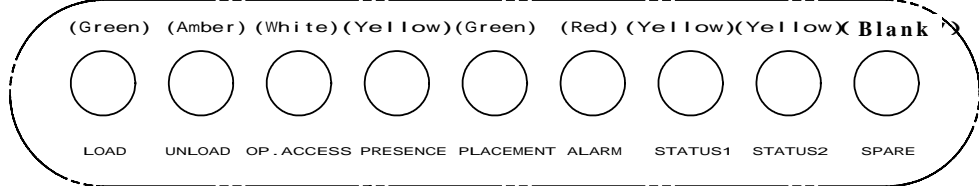
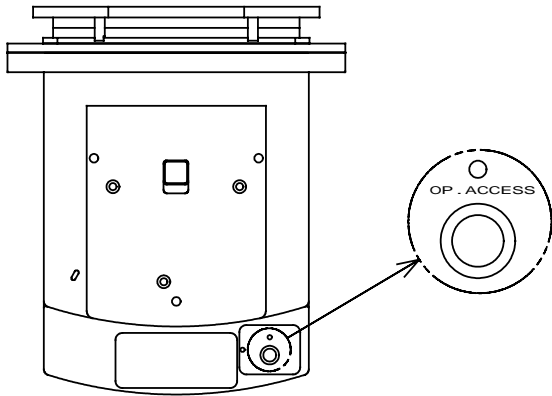

3-8 External View

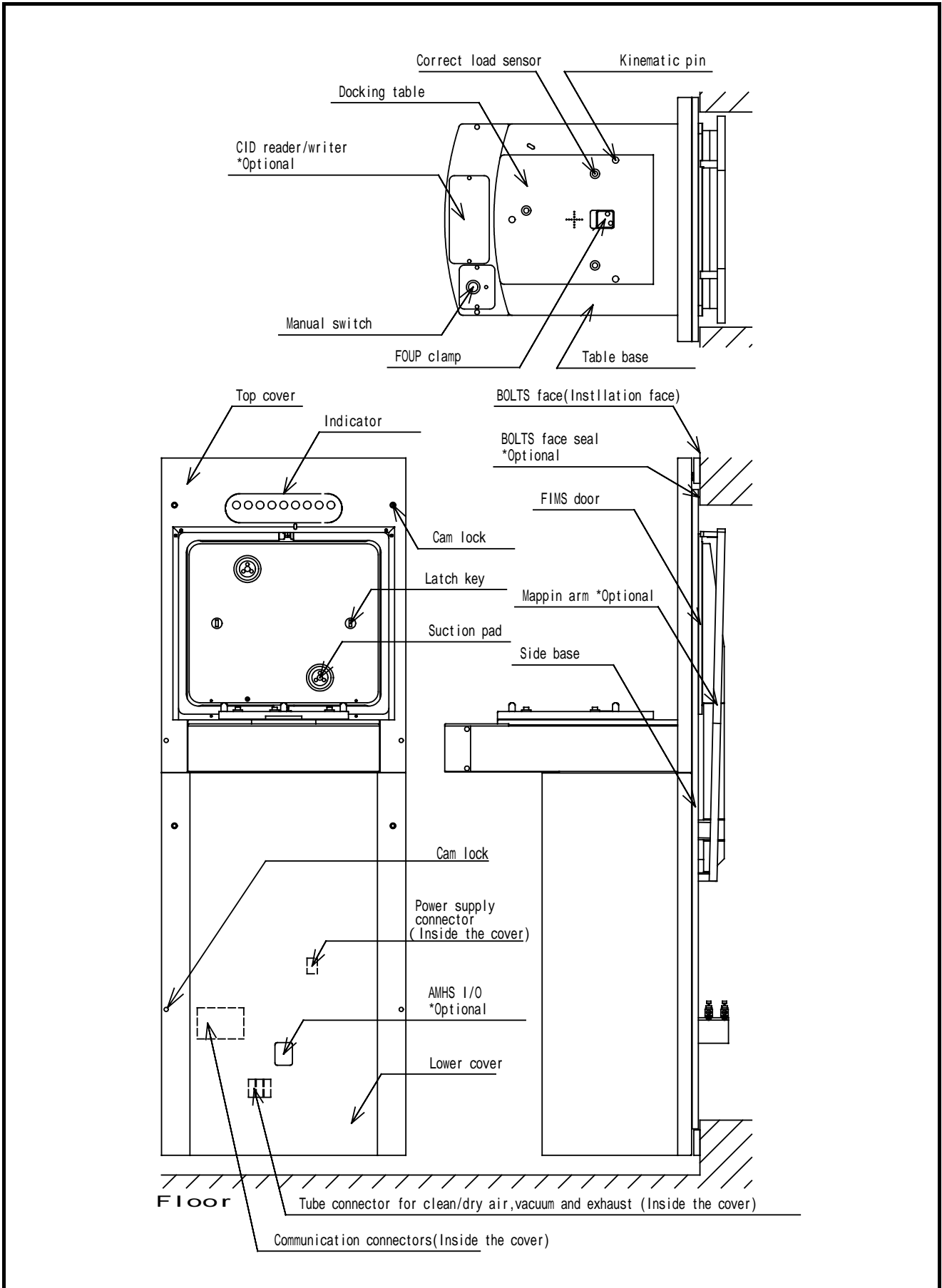

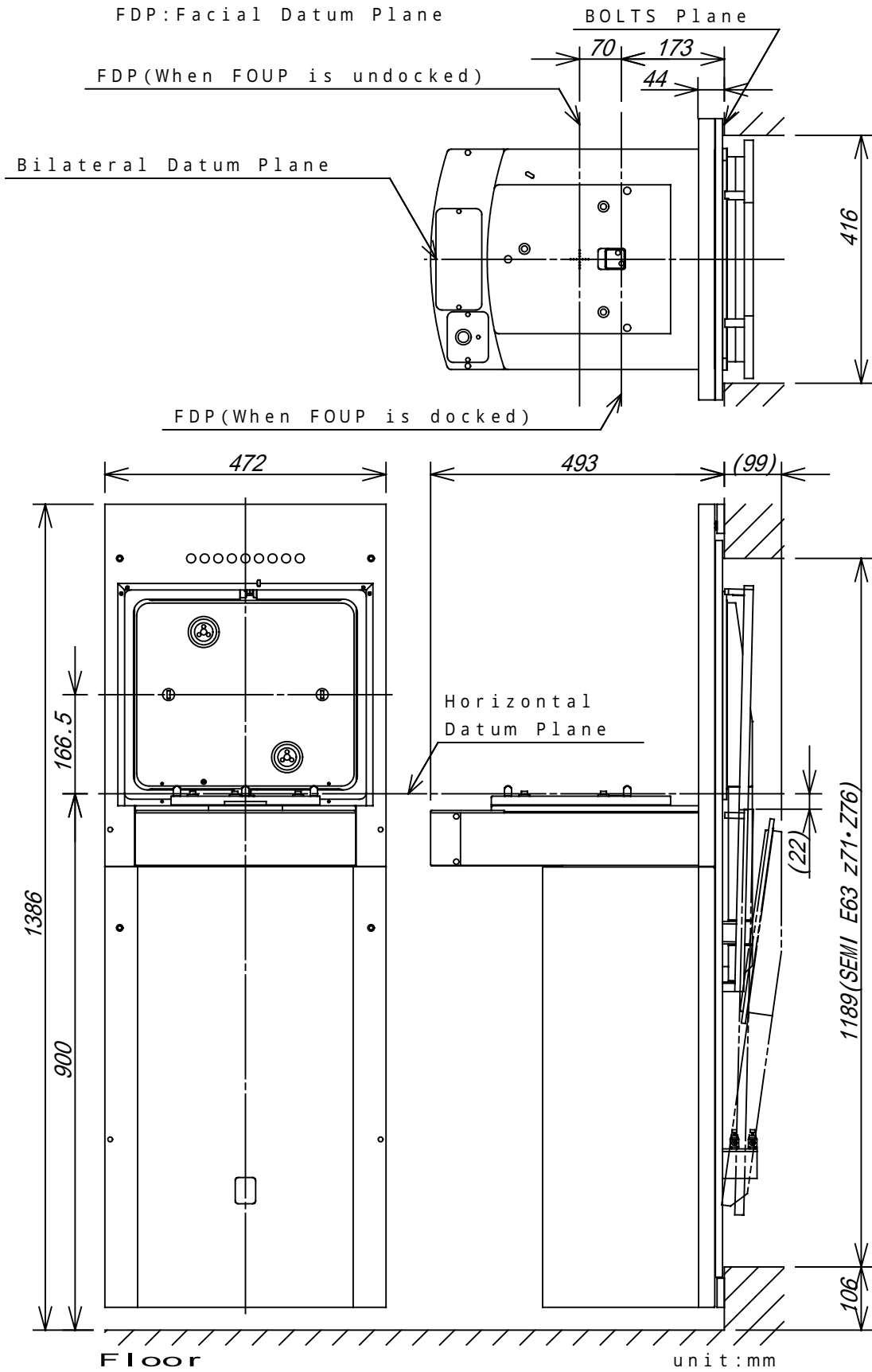

4. Installation Environment

4-1 Mechanical Interface

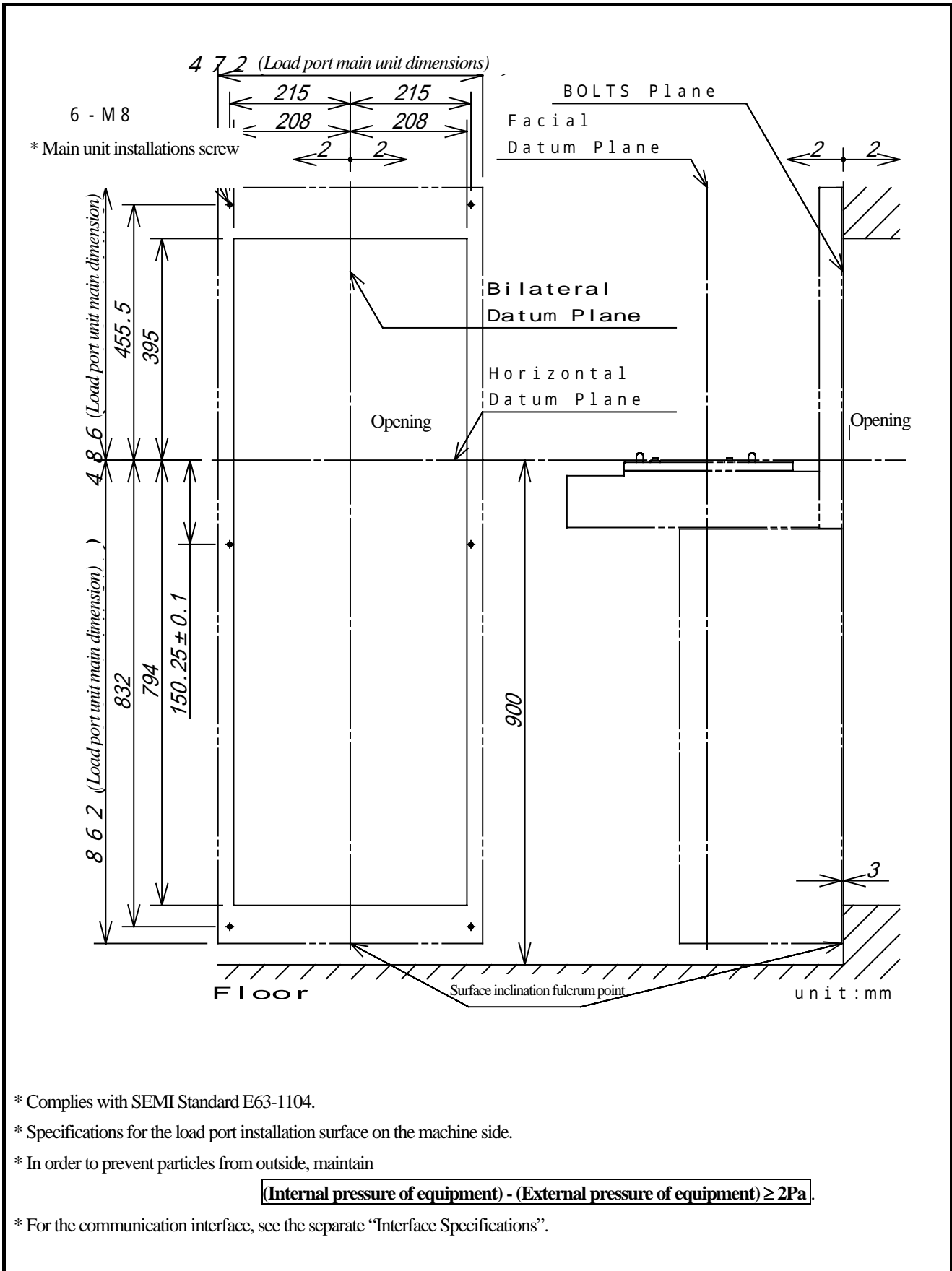

* Complies with SEMI Standard E63-1104.

* Specifications for the load port installation surface on the machine side.

* In order to prevent particles from outside, maintain

$$(\text{Internal pressure of equipment}) - (\text{External pressure of equipment}) \geq 2\text{Pa}$$

* For the communication interface, see the separate "Interface Specifications".

4-2 Working Area

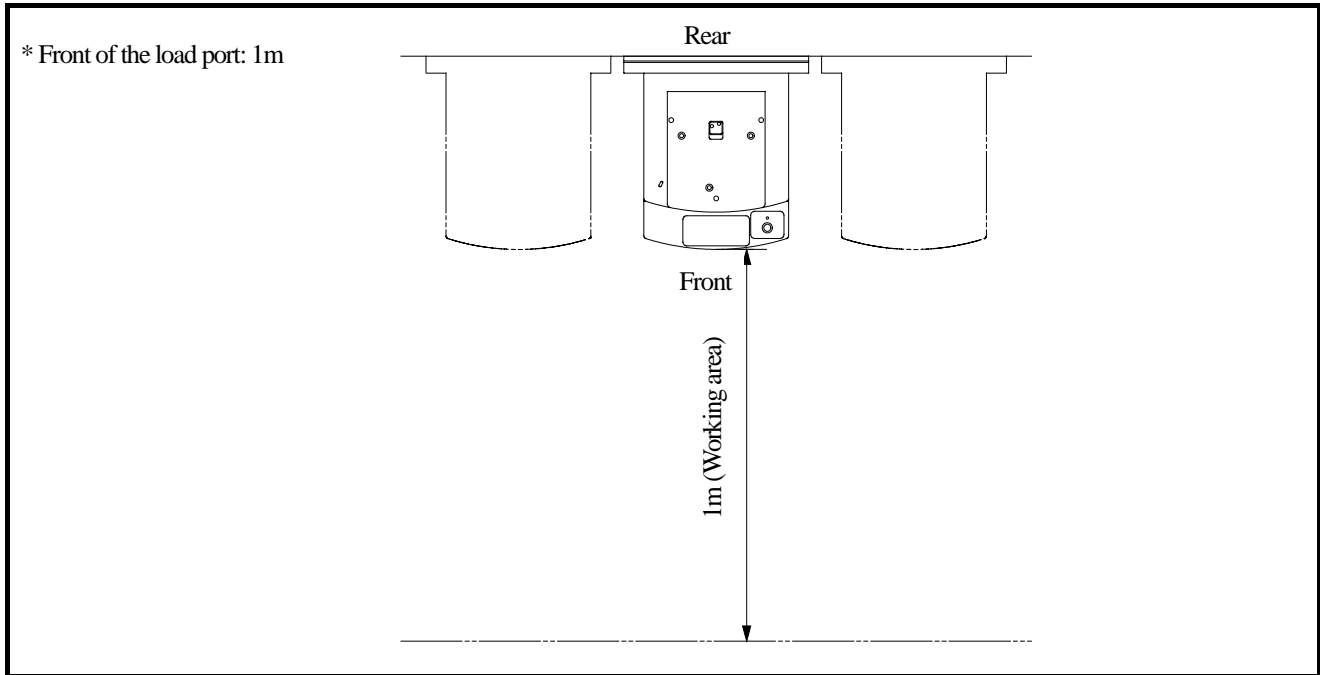

4-3 Preparation

(1) Installation tools

- Level
- Plum bob
- Square (Recommended: 300mm with frame)
- Scale (1,000mm)
- Parallel bar (Recommended: L=250mm, H=35mm, W=25mm)
- General tools
- Load port installation jigs (Optional: S54F1550: TDK)
- Horizontal jig (Recommended: Load port Horizon Calibration Jig (99MC104A: Nikon))

(2) Operation check

- Power cable: Connector 206060-1, Pin 66101-1 (Tyco Electronics AMP)
- Air tube: OD6mm (Clean/dry air source)
- Air tube: OD6mm (Vacuum source)
- Air tube: OD6mm (Exhaust)
- PC: Windows95 · 98 · ME · NT4.0 · 2000 · XP with serial I/F
- RS232C cable: D-sub 9-Pin cross-cable
- Maintenance tools: Recorded in the CD-ROM Manual

4-4 Accessories

- Adjustment plate A/B
- Installation jigs (1 for each left and right): Included in the first purchase
- Manual (CD-ROM or booklet)
- Interlock override key
- Mechanical stopper
- Inspection record form
- Electrical setting management table

5. Options

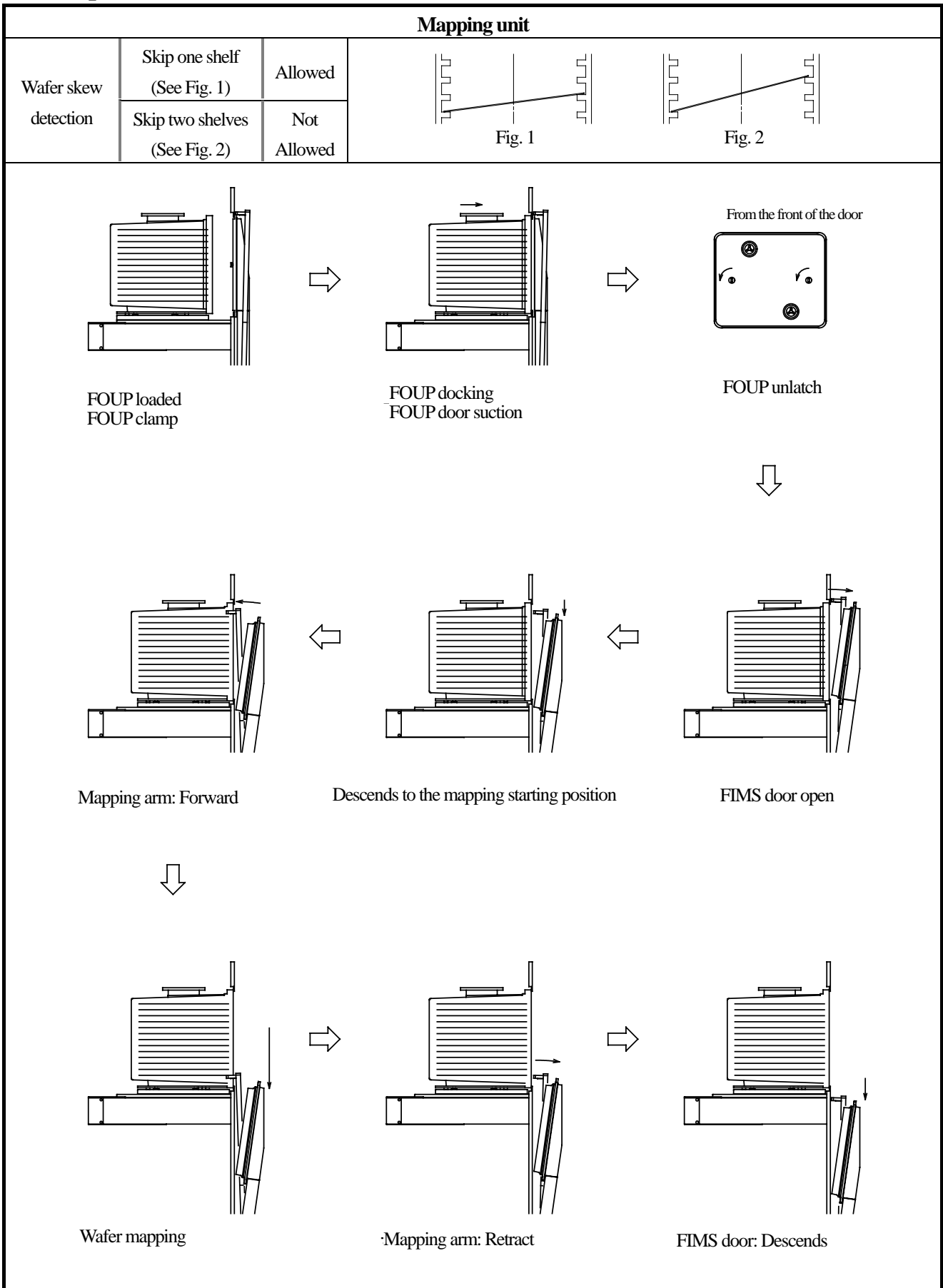

Power cable		
Connector name CNA1	Connector	206060-1 (Tyco Electronics AMP)
	Contact pin	66101-1 (Tyco Electronics AMP)
Fitting tool		58495-1 (Tyco Electronics AMP)
Cable clamp		206062-1 (Tyco Electronics AMP)
Wire		RO-FLEX 1100T AWG19 3 cores (Nichigoh Communication Electric Wire)
Wire length		2m/4m/6m
Other		
Carrier ID Reader/Writer	KEYENCE	BL-601
	OMRON	V700-HMD13A · V640
	Hermos	TLG-L1 · TLG-S1
	ASYST	ATR9000/9100 · PB-90
	* For other CID, contact TDK.	
AMHS (Optical I/O)		DMS-HB1 · DMG-HB1 (Hokuyo Automatic)
Info Pad Pin	Info Pad A · B	Electrical detection/Lock out pin
	Info Pad C · D	Lock out pin
Overlapped wafer sensor		·Detects if two wafers are stacked in a slot. For details, contact TDK.
Quartz glass wafer protrusion sensor		·The detection characteristics differ depending on the FOUP used. For details, contact TDK.
BOLTS surface seal material		T/#9096-TB-54 (Nichias)
CE marking		·For details, contact TDK.
Load port installation jig		·For details, contact TDK.

6. Warnings, Cautions and Notes on Operation Safety

TDK provides an instruction manual that describes product characteristics and specifications. To ensure safe operation and to prevent accidents by operating the machine incorrectly, please read carefully the instruction manual before using the product. Contact TDK for a copy of the instruction manual.