



MULTILAYER CERAMIC CHIP CAPACITORS



CKD Series Low ESL Feed Through Type

Type: CKD110JB
CKD310JB
CKD510JB
CKD610JB
CKD61BJB

Issue date: April 2011

**TDK MLCC
US Catalog**

Version B11

REMINDERS

Please read before using this product

SAFETY REMINDERS



REMINDERS

1. If you intend to use a product listed in this catalog for a purpose that may cause loss of life or other damage, you must contact our company's sales window.
2. We may modify products or discontinue production of a product listed in this catalog without prior notification.
3. We provide "Delivery Specification" that explain precautions for the specifications and safety of each product listed in this catalog. We strongly recommend that you exchange these delivery specifications with customers that use one of these products.
4. If you plan to export a product listed in this catalog, keep in mind that it may be a restricted item according to the "Foreign Exchange and Foreign Trade Control Law". In such cases, it is necessary to acquire export permission in harmony with this law.
5. Any reproduction or transferring of the contents of this catalog is prohibited without prior permission from our company.
6. We are not responsible for problems that occur related to the intellectual property rights or other rights of our company or a third party when you use a product listed in this catalog. We do not grant license of these rights.
7. This catalog only applies to products purchased through our company or one of our company's official agencies. This catalog does not apply to products that are purchased through other third parties.



CKD Series

Low ESL Feed Through Type

Type: CKD610JB (C1608), CKD510JB (C2012), CKD110JB (C3212), CKD310JB (C3216), CKD61BJB (C1608)

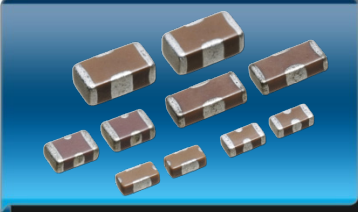

Features



- These small low-cost filters are used for meeting EMC requirements
- Can be used at higher frequencies due to low parasitic inductance
- Optimized for use as a noise bypass capacitor for signal and power source circuits

Structure

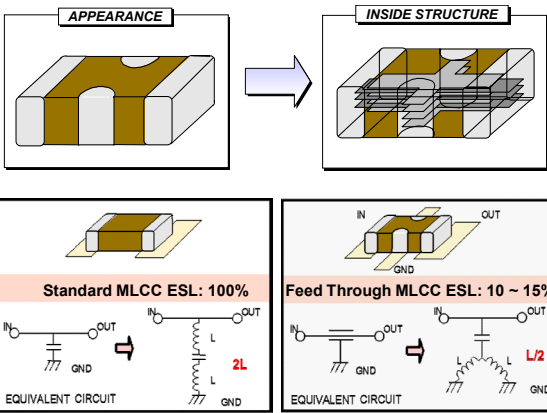

Applications



- Decoupling CPU power line
- High speed digital IC/decoupling
- High impedance/high current circuits
- DC to DC converter input/output smoothing
- Power supply

Shape & Dimensions

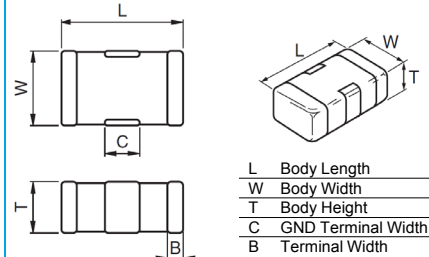

Dimensions in mm



Part Number Construction

CKD510JB 0J 226 S T XXXX

Series Name

Case Code	Length	Width
CKD610JB	1.60 ± 0.10	0.80 ± 0.10
CKD510JB	2.00 ± 0.20	1.25 ± 0.20
CKD110JB	3.20 ± 0.20	1.25 ± 0.20
CKD310JB	3.20 ± 0.20	1.60 ± 0.20
CKD61BJB	1.60 ± 0.10	0.80 ± 0.10

Rated Voltage (DC)

Voltage Code	Voltage (DC)
0J	6.3V
1A	10V
1C	16V
1E	25V
1H	50V

Internal Codes

Packaging Style

Packaging Code	Style
T	Tape & Reel

Capacitance Tolerance

Tolerance Code	Tolerance
S	+50/-20%

Nominal Capacitance (pF)

The capacitance is expressed in three digit codes and in units of pico Farads (pF). The first and second digits identify the first and second significant figures of the capacitance. The third digit identifies the multiplier. R designates a decimal point.

Capacitance Code	Capacitance
0R5	0.5pF
010	1pF
102	1,000pF (1nF)
105	1,000,000pF (1μF)



Capacitance Range Chart

CKD610JB [EIA CC0603]

Capacitance Range Chart

Rated Voltage: 6.3V (0J)

Capacitance (pF)	Cap Code	Tolerance	0J (6.3V)
470,000	474	S: +50/-20%	
1,000,000	105		
2,200,000	225		
4,700,000	475		
10,000,000	106		

Standard Thickness

0.80 mm



Capacitance Range Table

CKD610JB [EIA CC0603]

TDK Part Number (Ordering Code)	Rated Voltage	Capacitance (pF)	Capacitance Tolerance	Thickness (mm)	Rated Current (I _{dc} max)	DC Resistance (max)
CKD610JB0J105S	6.3V	1,000,000	+50/-20%	0.80 ± 0.10	2,000 mA	12 mΩ
CKD610JB0J225S	6.3V	2,200,000	+50/-20%	0.80 ± 0.10	2,000 mA	12 mΩ
CKD610JB0J475S	6.3V	4,700,000	+50/-20%	0.80 ± 0.10	2,000 mA	12 mΩ



Capacitance Range Chart

CKD510JB [EIA CC0805]

Capacitance Range Chart

Rated Voltage: 50V (1H), 25V (1E), 16V (1C), 10V (1A), 6.3V (0J)

Capacitance (pF)	Cap Code	Tolerance	1H (50V)	1E (25V)	1C (16V)	1A (10V)	0J (6.3V)
22	220	S: +50/-20%	■				
47	470						
100	101						
220	221						
470	471						
1,000	102						
2,200	222						
4,700	472						
10,000	103				■		
22,000	223				■		
47,000	473				■		
100,000	104					■	
470,000	474					■	
1,000,000	105						■
2,200,000	225						■
4,700,000	475						■
10,000,000	106						■
22,000,000	226						■

Standard Thickness
 0.85 mm



Capacitance Range Table

CKD510JB [EIA CC0805]

TDK Part Number (Ordering Code)	Rated Voltage	Capacitance (pF)	Capacitance Tolerance	Thickness (mm)	Rated Current (I _{dc} max)	DC Resistance (max)
CKD510JB1H220S	50V	22	+50/-20%	0.85 ± 0.15	400 mA	500 mΩ
CKD510JB1H470S	50V	47	+50/-20%	0.85 ± 0.15	400 mA	500 mΩ
CKD510JB1H101S	50V	100	+50/-20%	0.85 ± 0.15	400 mA	500 mΩ
CKD510JB1H221S	50V	220	+50/-20%	0.85 ± 0.15	400 mA	500 mΩ
CKD510JB1H471S	50V	470	+50/-20%	0.85 ± 0.15	400 mA	500 mΩ
CKD510JB1H102S	50V	1,000	+50/-20%	0.85 ± 0.15	400 mA	500 mΩ
CKD510JB1H222S	50V	2,200	+50/-20%	0.85 ± 0.15	400 mA	500 mΩ
CKD510JB1H472S	50V	4,700	+50/-20%	0.85 ± 0.15	400 mA	500 mΩ
CKD510JB1E103S	25V	10,000	+50/-20%	0.85 ± 0.15	1,000 mA	80 mΩ
CKD510JB1E223S	25V	22,000	+50/-20%	0.85 ± 0.15	1,000 mA	80 mΩ
CKD510JB1E473S	25V	47,000	+50/-20%	0.85 ± 0.15	1,000 mA	80 mΩ
CKD510JB1E104S	25V	100,000	+50/-20%	0.85 ± 0.15	1,000 mA	80 mΩ
CKD510JB1C474S	16V	470,000	+50/-20%	0.85 ± 0.15	2,000 mA	30 mΩ
CKD510JB1A105S	10V	1,000,000	+50/-20%	0.85 ± 0.15	2,000 mA	12 mΩ
CKD510JB1A225S	10V	2,200,000	+50/-20%	0.85 ± 0.15	2,000 mA	12 mΩ
CKD510JB1A475S	10V	4,700,000	+50/-20%	0.85 ± 0.15	3,000 mA	12 mΩ
CKD510JB0J106S	6.3V	10,000,000	+50/-20%	0.85 ± 0.15	4,000 mA	5 mΩ
CKD510JB0J226S	6.3V	22,000,000	+50/-20%	0.85 ± 0.15	4,000 mA	5 mΩ



Capacitance Range Chart

CKD110JB [EIA CC1205]

Capacitance Range Chart

Rated Voltage: 25V (1E)

Capacitance (pF)	Cap Code	Tolerance	1E (25V)
22	220	S: +50/-20%	[Yellow Bar]
47	470		
100	101		
220	221		
470	471		
1,000	102		
2,200	222		
4,700	472		
10,000	103		
22,000	223		
47,000	473		
100,000	104		

Standard Thickness

[Yellow Bar] 0.85 mm



Capacitance Range Table

CKD110JB [EIA CC1205]

TDK Part Number (Ordering Code)	Rated Voltage	Capacitance (pF)	Capacitance Tolerance	Thickness (mm)	Rated Current (I _{dc} max)	DC Resistance (max)
CKD110JB1E220S	25V	22	+50/-20%	0.85 ± 0.15	200 mA	600 mΩ
CKD110JB1E470S	25V	47	+50/-20%	0.85 ± 0.15	200 mA	600 mΩ
CKD110JB1E101S	25V	100	+50/-20%	0.85 ± 0.15	200 mA	600 mΩ
CKD110JB1E221S	25V	220	+50/-20%	0.85 ± 0.15	200 mA	600 mΩ
CKD110JB1E471S	25V	470	+50/-20%	0.85 ± 0.15	200 mA	600 mΩ
CKD110JB1E102S	25V	1,000	+50/-20%	0.85 ± 0.15	200 mA	600 mΩ
CKD110JB1E222S	25V	2,200	+50/-20%	0.85 ± 0.15	200 mA	600 mΩ
CKD110JB1E472S	25V	4,700	+50/-20%	0.85 ± 0.15	200 mA	600 mΩ
CKD110JB1E103S	25V	10,000	+50/-20%	0.85 ± 0.15	500 mA	300 mΩ
CKD110JB1E223S	25V	22,000	+50/-20%	0.85 ± 0.15	500 mA	300 mΩ
CKD110JB1E473S	25V	47,000	+50/-20%	0.85 ± 0.15	500 mA	300 mΩ
CKD110JB1E104S	25V	100,000	+50/-20%	0.85 ± 0.15	500 mA	300 mΩ



Capacitance Range Chart

CKD310JB [EIA CC1206]

Capacitance Range Chart

Rated Voltage: 16V (1C), 6.3V (0J)

Capacitance (pF)	Cap Code	Tolerance	1C (16V)	0J (6.3V)
100,000	104	S: +50/-20%		
220,000	224			
470,000	474			
1,000,000	105			
22,000,000	226			

Standard Thickness

1.30 mm



Capacitance Range Table

CKD310JB [EIA CC1206]

TDK Part Number (Ordering Code)	Rated Voltage	Capacitance (pF)	Capacitance Tolerance	Thickness (mm)	Rated Current (I _{dc} max)	DC Resistance (max)
CKD310JB1C104S	16V	100,000	+50/-20%	1.30 ± 0.15	2,000 mA	40 mΩ
CKD310JB1C224S	16V	220,000	+50/-20%	1.30 ± 0.15	2,000 mA	40 mΩ
CKD310JB1C474S	16V	470,000	+50/-20%	1.30 ± 0.15	2,000 mA	40 mΩ
CKD310JB1C105S	16V	1,000,000	+50/-20%	1.30 ± 0.15	2,000 mA	40 mΩ
CKD310JB0J226S	6.3V	22,000,000	+50/-20%	1.30 ± 0.15	4,000 mA	12 mΩ



Capacitance Range Chart

CKD61BJB [EIA CC0603]

Capacitance Range Chart

Rated Voltage: 6.3V (0J)

Capacitance (pF)	Cap Code	Tolerance	0J (6.3V)
100,000	104	S: +50/-20%	
470,000	474		
1,000,000	105		
4,700,000	475		
10,000,000	106		

Standard Thickness
 0.60 mm



Capacitance Range Table

CKD61BJB [EIA CC0603]

TDK Part Number (Ordering Code)	Rated Voltage	Capacitance (pF)	Capacitance Tolerance	Thickness (mm)	Rated Current (I _{dc} max)	DC Resistance (max)
CKD61BJB0J474S	6.3V	470,000	+50/-20%	0.60 ± 0.10	2,000 mA	30 mΩ
CKD61BJB0J105S	6.3V	1,000,000	+50/-20%	0.60 ± 0.10	2,000 mA	30 mΩ
CKD61BJB0J475S	6.3V	22,000,000	+50/-20%	0.60 ± 0.10	2,000 mA	12 mΩ



General Specifications

CKD Series – Feed Through Type

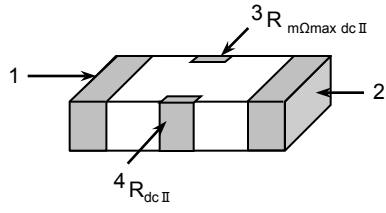
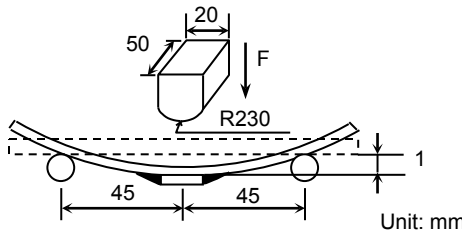
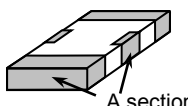
No.	Item	Performance	Test or Inspection Method					
1	External Appearance	No defects which may affect performance.	Inspect with magnifying glass (3×).					
2	Insulation Resistance	10,000MΩ or 500MΩ•μF min., whichever smaller (As for the capacitors of rated voltage 16, 10, 6.3V DC, 100MΩ•μF min.).	Apply rated voltage for 60s.					
3	Direct Current Resistance R_{dc} (1-2)	R_{dc} is between 5MΩ - 600 MΩ depending on item. See the Capacitance Range Chart section to obtain item specific parameters.	Measuring current should be 100mA max. 					
4	Voltage Proof	Withstand test voltage without insulation breakdown or other damage.	2.5 x rated voltage (DC) shall be applied for 1 to 5s. Charge / discharge current shall not exceed 50mA.					
5	Capacitance	Within the specified tolerance.	<table border="1"> <thead> <tr> <th>Measuring Frequency</th> <th>Measuring Voltage</th> </tr> </thead> <tbody> <tr> <td rowspan="2">1kHz±10%</td> <td>0.5 - 5 V_{rms}</td> </tr> <tr> <td>1.0±0.2V_{rms}</td> </tr> </tbody> </table>	Measuring Frequency	Measuring Voltage	1kHz±10%	0.5 - 5 V_{rms}	1.0±0.2 V_{rms}
Measuring Frequency	Measuring Voltage							
1kHz±10%	0.5 - 5 V_{rms}							
	1.0±0.2 V_{rms}							
6	Dissipation Factor (D.F.)	10% maximum	See No.5 in this table for measuring condition.					
7	Bending	No mechanical damage.	Reflow solder the capacitor on P.C. board (shown in Appendix 2, Appendix 4 or Appendix 6) and bend 1mm. 					
8	Solderability	New solder to cover over 75% of termination. 25% may have pin holes or rough spots but not concentrated in one spot. Ceramic surface of "A sections" shall not be exposed due to melting or shifting of termination material. 	Completely soak both terminations in solder at 235±5°C for 2±0.5s. Solder: H63A (JIS Z 3282) Flux: Isopropyl alcohol (JIS K 8839) Rosin (JIS K 5902) 25% solid solution.					



General Specifications

CKD Series – Feed Through Type

No.	Item	Performance	Test or Inspection Method														
9	Resistance to solder heat		Completely soak both terminations in solder at $260 \pm 5^\circ\text{C}$ for $5 \pm 1\text{s}$. Preheating condition Temp.: $150 \pm 10^\circ\text{C}$ Time: 1 to 2min. Flux: Isopropyl alcohol (JIS K 8839) Rosin (JIS K 5902) 25% solid solution. Solder: H63A (JIS Z 3282) Leave the capacitor in ambient conditions for $24 \pm 2\text{h}$ before measurement.														
	External appearance	No mechanical damage.															
	Capacitance	Change from the value before test $\pm 7.5\%$															
	D.F. (Class 2)	Meet the initial spec.															
	Insulation Resistance	Meet the initial spec.															
	Voltage Proof	No insulation breakdown or other damage.															
	Resistance for DC (R_{dc})	1.0Ω max.															
10	Temperature cycle		Reflow solder the capacitor on P.C. board (shown in Appendix 1 or Appendix 3) before testing. Expose the capacitor in the conditions step1 through step 4 and repeat 5 times consecutively. Leave the capacitor in ambient conditions for $24 \pm 2\text{h}$ before measurement.														
	External appearance	No mechanical damage.															
	Capacitance	Change from the value before test $\pm 7.5\%$															
	D.F. (Class 2)	Meet the initial spec.															
	Insulation Resistance	Meet the initial spec.															
	Resistance for DC (R_{dc})	1.0Ω max.															
				<table border="1"> <thead> <tr> <th>Step</th> <th>Temperature ($^\circ\text{C}$)</th> <th>Time (min.)</th> </tr> </thead> <tbody> <tr> <td>1</td> <td>Min. operating temp. ± 3</td> <td>30 ± 3</td> </tr> <tr> <td>2</td> <td>20 ± 2</td> <td>2 - 5</td> </tr> <tr> <td>3</td> <td>Max. operating temp. ± 2</td> <td>30 ± 2</td> </tr> <tr> <td>4</td> <td>20 ± 2</td> <td>2 - 5</td> </tr> </tbody> </table>	Step	Temperature ($^\circ\text{C}$)	Time (min.)	1	Min. operating temp. ± 3	30 ± 3	2	20 ± 2	2 - 5	3	Max. operating temp. ± 2	30 ± 2	4
Step	Temperature ($^\circ\text{C}$)	Time (min.)															
1	Min. operating temp. ± 3	30 ± 3															
2	20 ± 2	2 - 5															
3	Max. operating temp. ± 2	30 ± 2															
4	20 ± 2	2 - 5															
11	Moisture Resistance (Steady State)		Reflow solder the capacitors on P.C. board (shown in Appendix 1 or Appendix 3) before testing. Leave at temperature $40 \pm 2^\circ\text{C}$, 90 to 95%RH for 500 +24,0h. Leave the capacitor in ambient conditions for $24 \pm 2\text{h}$ before measurement.														
	External appearance	No mechanical damage.															
	Capacitance	Change from the value before test $\pm 12.5\%$															
	D.F. (Class 2)	200% of initial spec. max.															
	Insulation Resistance	1,000M Ω or 50M $\Omega \cdot \mu\text{F}$ min, whichever smaller. (As for the capacitors of rated voltage 16, 10, 6.3V DC, 10M $\Omega \cdot \mu\text{F}$ min.)															
	Resistance for DC (R_{dc})	1.0Ω max.															



No.	Item	Performance	Test or Inspection Method
12	Life		
	External appearance	No mechanical damage.	Reflow solder the capacitor on P.C. board (shown in Appendix 1, Appendix 3 or Appendix 5) before testing. Voltage shall be applied at maximum operating temperature $\pm 2^{\circ}\text{C}$ for 1,000 +48, 0h.
	Capacitance	Change from the value before test $\pm 15\%$	Applied voltage is 1xRV; however some items may be tested at higher voltage (1.2x, 1.5x or 2xRV). Charge/discharge current shall not exceed 50mA.
	D.F. (Class 2)	200% of initial spec. max.	Leave the capacitor in ambient conditions for $24 \pm 2\text{h}$ before measurement.
	Insulation Resistance	1,000M Ω or 50M $\Omega \cdot \mu\text{F}$ min., whichever smaller. (As for the capacitors of rated voltage 16, 10, 6.3V DC, 10M $\Omega \cdot \mu\text{F}$ min.)	Voltage conditioning: Voltage treats the capacitor under testing temperature and voltage for 1 hour.
	Resistance for DC (R_{dc})	1.0 Ω max.	Leave the capacitor in ambient conditions for $24 \pm 2\text{h}$ before measurement. Use this measurement for initial value.

***As for the initial measurement of capacitors on number 9, 10 and 11, leave capacitors at 150 \pm 10, 0 $^{\circ}\text{C}$ for 1 hour and measure the value after leaving capacitors for 24 \pm 2h in ambient condition.**



CKD Series – Feed Through Type

Appendix - 1

P.C. Board for reliability test

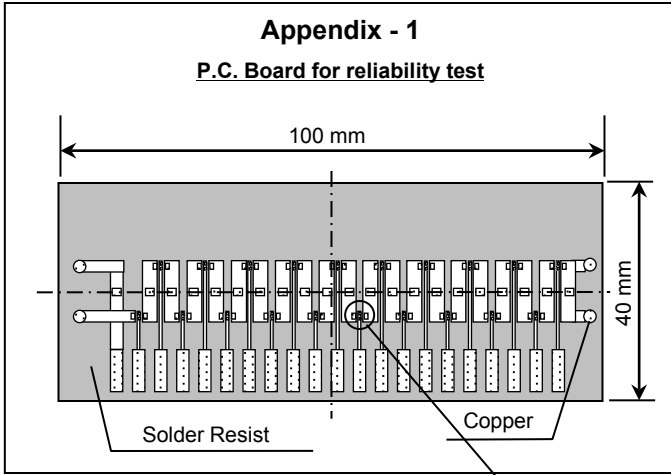

Appendix - 2

P.C. Board for bending test

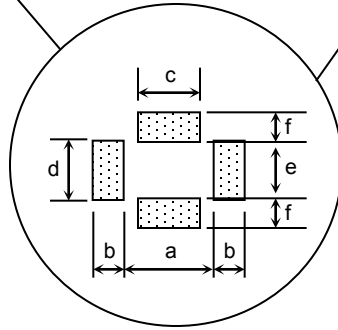
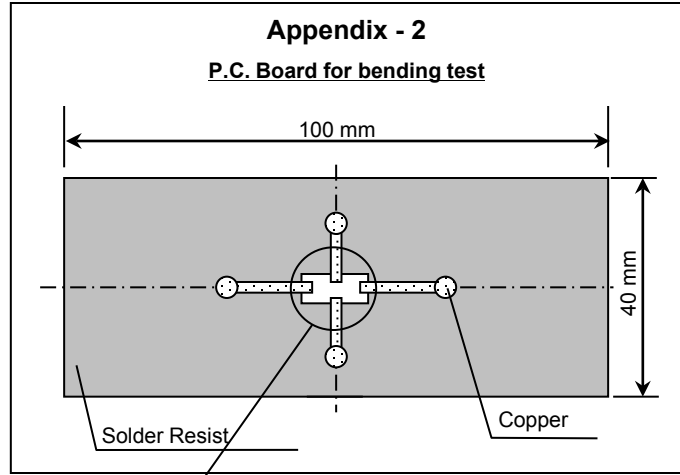



Appendix – 1 & 2

Case Code			Dimensions (mm)					
Series	JIS	EIA	a	b	c	d	e	f
CKD710JB	C1005	CC0402	0.7	0.3	0.19	0.6	0.25	0.25

Material: Glass Epoxy (As per JIS C6484 GE4)

P.C. Board thickness: 1.6mm

-  Copper (thickness 0.035mm)
-  Solder resist



Appendix - 3

P.C. Board for reliability test

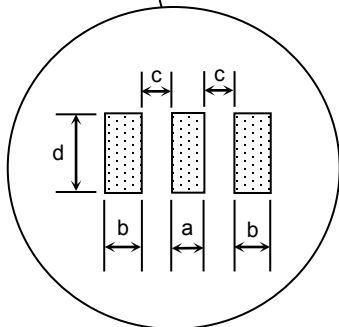
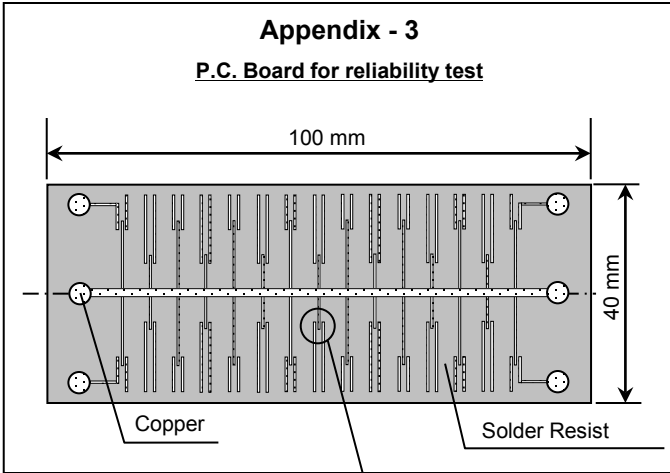

Appendix - 4

P.C. Board for bending test

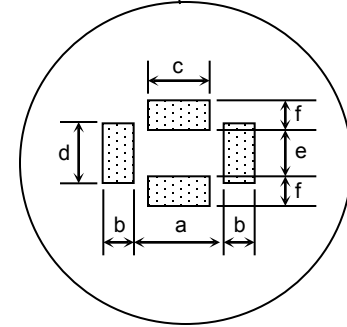
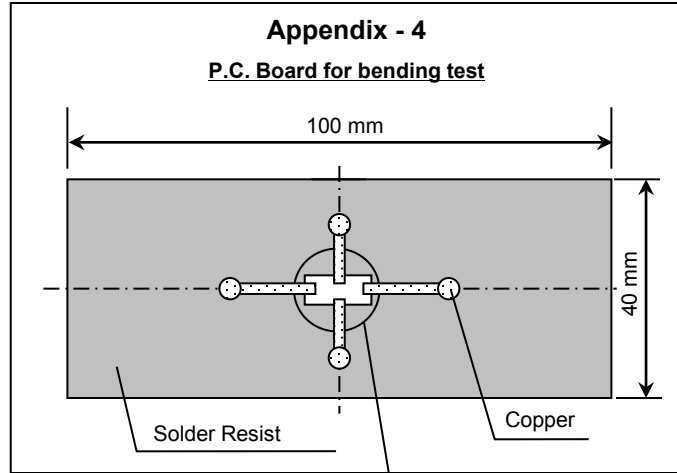

(Unit: mm)

Appendix - 3

Case Code			Dimensions (mm)					
Series	JIS	EIA	a	b	c	d	e	f
CKD610JB	C1608	CC0603	1.0	0.6	0.4	0.6	0.4	0.4

Appendix - 4

Case Code			Dimensions (mm)			
Series	JIS	EIA	a	b	c	d
CKD610JB	C1608	CC0603	0.4	0.5	0.4	2.0

Material: Glass Epoxy (As per JIS C6484 GE4)

P.C. Board thickness: 1.6mm

- Copper (thickness 0.035mm)
- Solder resist



Appendix - 5

P.C. Board for reliability test

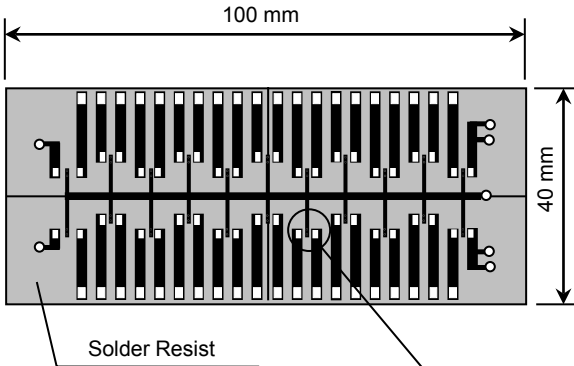

Appendix - 6

P.C. Board for bending test

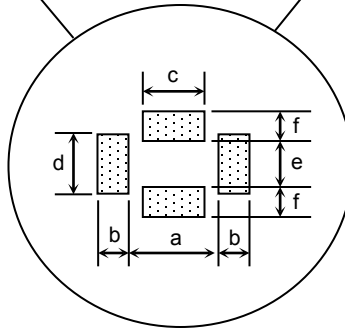
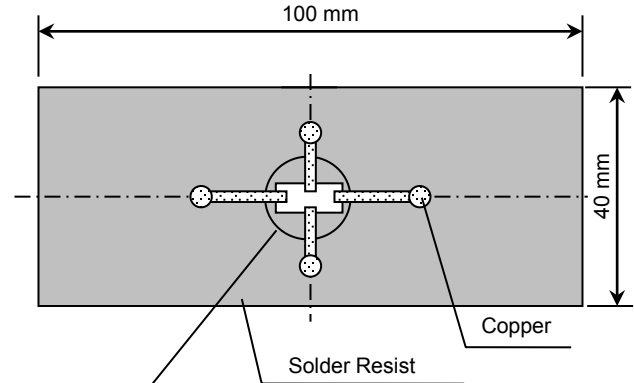

Appendix – 5 & 6

Series	Case Code		Dimensions (mm)					
	JIS	EIA	a	b	c	d	e	f
CKD510JB	C2012	CC0805	1.4	0.6	0.5	0.8	0.6	0.65
CKD110JB	C3212	CC1205	2.5	0.7	1.4	1.0	0.6	0.7
CKD310JB	C3216	CC1206	2.5	1.2	1.4	1.3	0.8	0.9

Material: Glass Epoxy (As per JIS C6484 GE4)

P.C. Board thickness: 1.6mm

- Copper (thickness 0.035mm)
- Solder resist

Soldering Information

CKD Series – Feed Through Type

Recommended Soldering Land Pattern

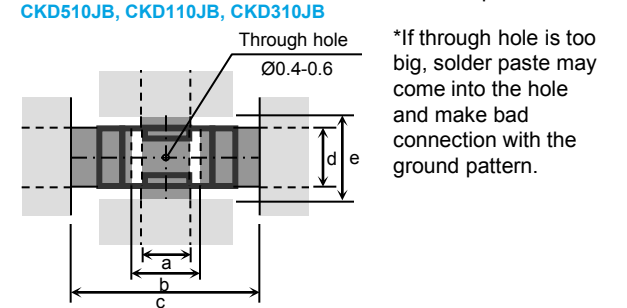
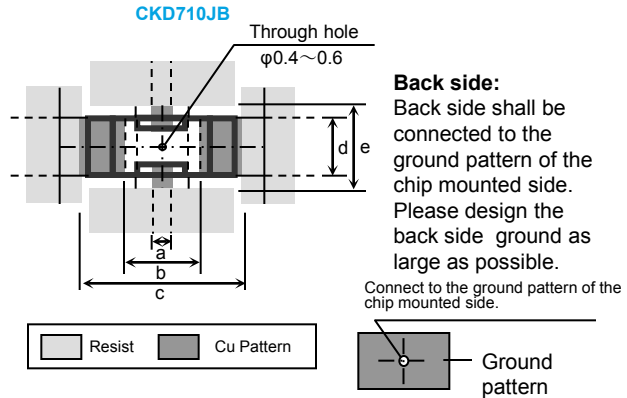

Symbol	a	b	c	d	e
Series CKD710JB	0.19	0.7	1.3	0.6	0.75
Series CKD510JB	0.5	1.5	2.6	1.0	2.0
Series CKD110JB	1.4	2.5	4.5	1.0	2.0
Series CKD310JB	1.4	2.5	4.5	1.2	2.4

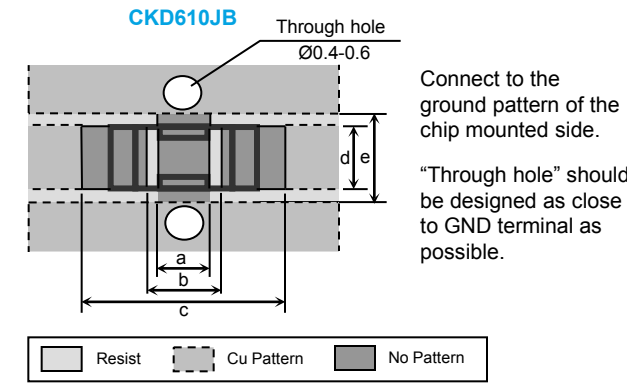

Symbol	a	b	c	d	e
Series CKD610JB	0.4	1.2	2.2	0.7	1.4

Recommended Soldering Profile

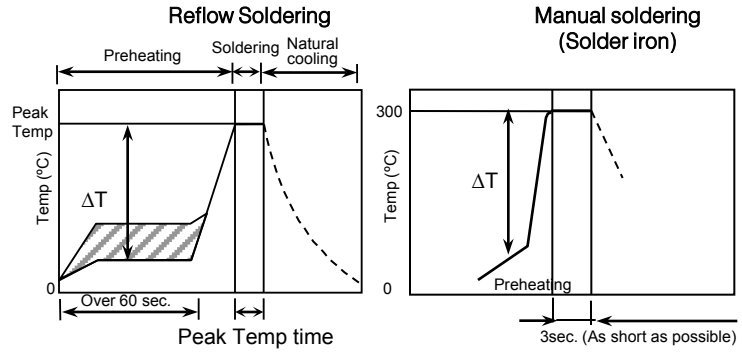

Recommended soldering duration

Solder	Temp./Dura.	Reflow Soldering	
		Peak temp (°C)	Duration (sec.)
Sn-Pb Solder		230 max.	20 max.
Lead-Free Solder		260 max.	10 max.

Recommended solder compositions

- Sn-37Pb (Sn-Pb solder)
- Sn-3.0Ag-0.5Cu (Lead Free Solder)

Preheating Condition

Soldering Method	Temperature (°C)
Reflow soldering	$\Delta T \leq 150$
Manual soldering	$\Delta T \leq 150$

Recommended Solder Amount

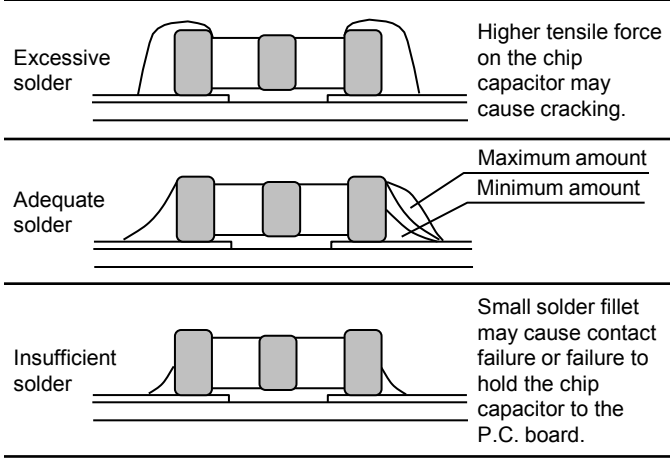



Packaging Information

CKD Series – Feed Through Type

Carrier Tape Configuration

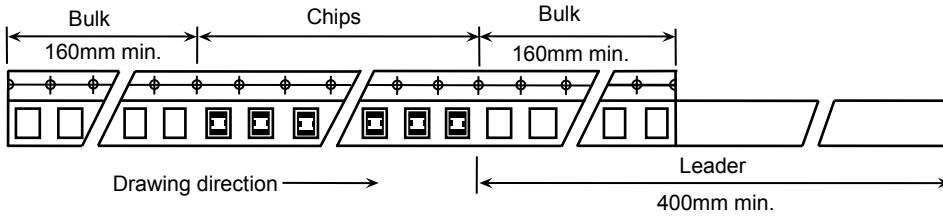

Peel Back Force (Top Tape)

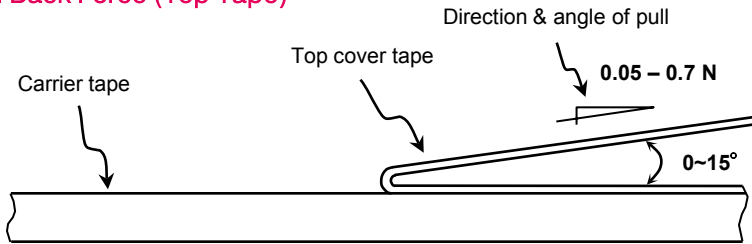

- Carrier tape shall be flexible enough to be wound around a minimum radius of 30mm with components in tape.
- The missing of components shall be less than 0.1%
- Components shall not stick to the cover tape.
- The cover tape shall not protrude beyond the edges of the carrier tape not shall cover the sprocket holes.

Chip Quantity Per Reel and Structure of Reel (Paper & Plastic)

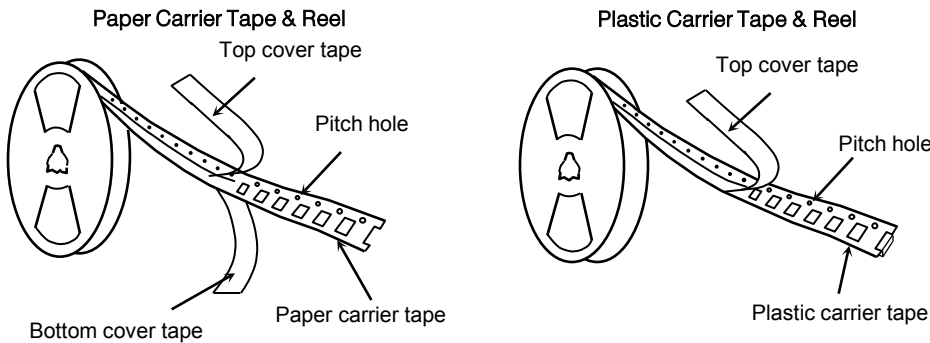

Case Code			Chip Thickness (mm)	Taping Material	Chip quantity (pcs.)	
Series	JIS	EIA			φ178mm (7") reel	φ330mm (13") reel
CKD710JB	C1005	CC0402	0.30	Paper	10,000	50,000
CKD610JB	C1608	CC0603	0.80		4,000	10,000
CKD510JB	C2012	CC0805	0.85			
CKD110JB	C3212	CC1205	0.85			
CKD310JB	C3216	CC1206	1.30	Plastic	2,000	



Additional Information

CKD Series – Feed Through Type

• Inside Structure & Material System

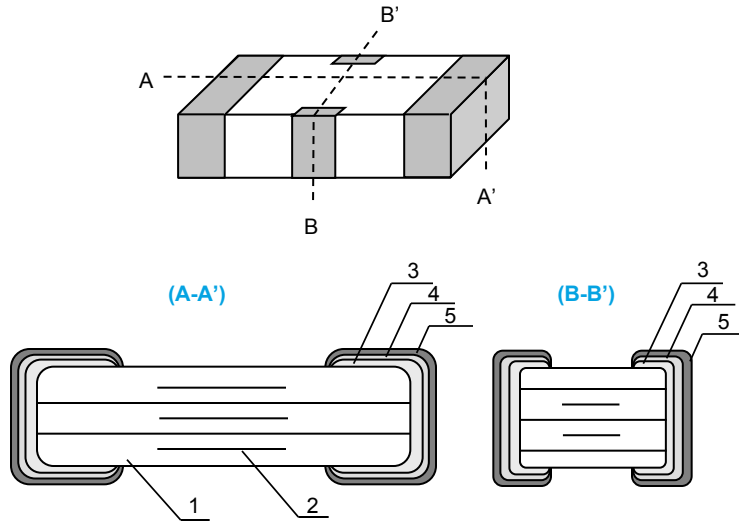

No.	NAME	MATERIAL
(1)	Ceramic Dielectric	CaZrO ₃ or BaTiO ₃
(2)	Internal Electrode	Nickel (Ni)
(3)	Termination	Copper (Cu)
(4)		Nickel (Ni)
(5)		Tin (Sn)

• Environmental Information

TDK Corporation established internal product environmental assurance standards that include the six hazardous substances banned by the EU RoHS Directive¹ enforced on July 1, 2006 along with additional substances independently banned by TDK and has successfully completed making general purpose electronic components conform to the RoHS Directive².

1. Abbreviation for Restriction on Hazardous Substances, which refers to the regulation EU Directive 2002/95/EC on hazardous substances by the European Union (EU) effective from July 1, 2006. The Directive bans the use of six specific hazardous substances in electric and electronic devices and products handled within the EU. The six substances are lead, mercury, cadmium, hexavalent chromium, PBB (polybrominated biphenyls), and PBDE (polybrominated diphenyl ethers).
2. This means that, in conformity with the EU Directive 2002/95/EC, lead, cadmium, mercury, hexavalent chromium, and specific bromine-based flame retardants, PBB and PBDE, have not been used, except for exempted applications.

For REACH (SVHC : 15 substances according to ECHA / October 2008) : All TDK MLCC do not contain these 15 substances.

For European Directive 2000/53/CE and 2005/673/CE : Cadmium, Hexavalent Chromium, Mercury, Lead are not contained in all TDK MLCC.

For European Directive 2003/11/CE : Pentabromodiphenyl-ether, Octabromodiphenyl-ether are not contained in all TDK MLCC.

• Shape & Dimensions

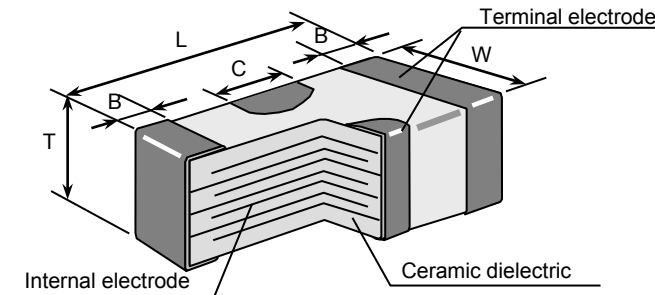

Case Code			Dimensions (mm)				
Series	JIS	EIA	L	W	T	B	C
CKD710JB	C1005	CC0402	1.00	0.55	0.30	0.17	0.30
CKD610JB	C1608	CC0603	1.60	0.80	0.80	0.10	0.40
CKD510JB	C2012	CC0805	2.00	1.25	0.85	0.30	0.40
CKD110JB	C3212	CC1205	3.20	1.25	0.85	0.40	0.95
CKD310JB	C3216	CC1206	3.20	1.60	1.30	0.40	0.95