



## Capacitance Measurement: Measurement Tips for High Capacitance MLCC's

Mark Waldrip and Richard Tse  
TDK Components USA, Inc.

### Abstract

As the available capacitance range for MLCC's continues to increase, better test equipment and measurement techniques are needed to make accurate measurements. This paper provides answers to frequently asked questions on high capacitance measurement.

# Measurement Tips for High Capacitance MLCC's

by Mark Waldrip and Richard Tse

## Introduction:

As the maximum capacitance values of Multilayer Ceramic Capacitors (MLCC's) continue to increase, the equipment which was used to measure capacitance in the past may not provide correct measurements on high cap components.

In particular, the meters cannot drive enough AC voltage to measure the full capacitance. The following discussion contains answers to frequently asked questions, as well as measurement tips on performing high cap measurements on MLCC's.

### Question 1: Why do I read low capacitance when measuring some high capacitance MLCC's?

When measuring capacitors, it is important to understand the difference between the *true* value, *effective* value, and *indicated* value. The *true* value is the value of the capacitor if it was an ideal component with no inductive and resistive elements. The *effective* value is the sum of the components real and reactive vectors, and is frequency dependent. The *indicated* value is the value displayed by the measurement equipment, and subject to measurement inaccuracies

When measuring high capacitance value components, the voltage level set at the meter, the indicated value, may not necessarily be equal to the voltage level delivered across the DUT, the effective value.

### Question 2: What voltage and frequency should I apply to the capacitor?

MLCC capacitors  $> 10\mu\text{F}$  are considered high capacitance. Improvements in manufacturing technology have allowed ceramic capacitor manufacturers to build higher capacitance parts approaching tantalum and electrolytic values. These "high value" MLCC's are specified under the same conditions as tantalum capacitors. The measurement voltage should be  $0.5 V_{\text{rms}}$  and measurement frequency should be 120Hz. The following table summarizes the measurement conditions.

Capacitance	AC Voltage	Frequency
$C \leq 1000\text{pF}$	$1.0 \pm 0.2 V_{\text{rms}}$	$1\text{MHz} \pm 10\%$
$1000\text{pF} < C \leq 10\mu\text{F}$	$1.0 \pm 0.2 V_{\text{rms}}$	$1\text{kHz} \pm 10\%$
$C > 10\mu\text{F}$	$0.5 \pm 0.2 V_{\text{rms}}$	$120 \text{ Hz} \pm 10\%$

Table 1: Measurement Conditions per TDK general specification.

### Question 3: How can I confirm that my voltage is correct?

The easiest method to verify voltage is by measuring the AC voltage ( $V_{\text{rms}}$ ) across the capacitor while the capacitor is being measured by the instrument (Fig.1).



Fig. 1: Verification of VAC.

If the measured voltage is below the lower limit requirement of  $0.8 V_{\text{rms}}$  while the capacitor measurement is being made, low capacitance may be observed. Some capacitance meters such as the HP4284A have Voltage and Current Level Monitors. (Fig.2). When these functions are "ON", the voltage level across the DUT, or the current through the DUT will be displayed directly on the instrument display, eliminating the need for connecting the voltmeter. *It is important to understand that the voltage delivered to the DUT can be very different from the set oscillator voltage level.*



Fig. 2: Voltage and Current level monitors on the HP4284A.

**Question 4:** How can a meter supply a different voltage than what is set?

The impedance of a capacitor can affect the capacitance measurement read from certain cap meters. The impedance (Z) formula for a capacitor is as follows:

$$Z(\Omega) = R + j (- 1/\omega C) \text{ where } \omega = 2\pi f \quad (\text{Formula 1})$$

Consequently, the frequency (f) and capacitance (C) will effect the impedance value for the device under test (DUT). As capacitance and frequency increase, the impedance of the DUT decreases. The cap meter's impedance should switch to a lower range to compensate for the lower impedance of the DUT. Some cap meters have several impedance settings to adequately compensate for different DUT impedances. However, not all cap meters are able to switch to appropriate lower impedance values. As a result, inaccurate capacitance readings can occur. In other words, a cap meter's fixed high impedance can cause lower capacitance measurements by not allowing the full voltage setting to reach the DUT.

**Question 5:** What is the recommended meter for measuring high capacitance MLCC's?

For accurate high cap measurements, the recommended meters are the HP4284A, HP4278A, or equivalent.

The HP4284A with the high power option (option 001) increases the rms source current level from 10 mA<sub>rms</sub> to 100 mA<sub>rms</sub>. With a higher current range, the meter has more power to maintain the rms voltage level applied to the DUT. The HP4284A also has Voltage and Current Level Monitors which show the actual voltage and current levels seen at the DUT. One

drawback from using the HP4284A is extended measurement time. The HP4284A uses a feedback configuration with the level monitor to maintain the full rms levels.

Measurement time for the HP4284A can be calculated from the following formula:

$$[(\text{meas\_time}_{\text{short}}) + (\sim 115\text{msec.})] \times n \quad (\text{Formula 2})$$

where n = 2 to 6.

If measurement speed is a greater concern than accuracy, the HP4278A is recommended. This meter does not have the ALC function or the Voltage and Current Level Monitors but AC Voltage can still be verified by using a voltmeter. The HP4278A is an earlier version of the HP4284A and is sometimes referred to as a "production " meter due to the faster measurement speed.

Again, the important point is that the meter must be able to supply the correct voltage to the DUT. This can be accomplished either by switching to a low output impedance range in order to compensate for the low impedance of high capacitance MLCC's, or by having a feature which automatically maintains the test level at the device under test.

**Question 6:** Can I automatically maintain the test level at the DUT?

The HP4284 has a feature known as Automatic Level Control (ALC). By activating this function, the set voltage level can be held constant at the DUT. When measuring high cap MLCC's with this instrument, make sure that the ALC feature is "ON" (Fig.3-4). Failing to turn this function on can result in capacitance readings that are mistakenly read low.



Fig. 3: Setting ALC On.

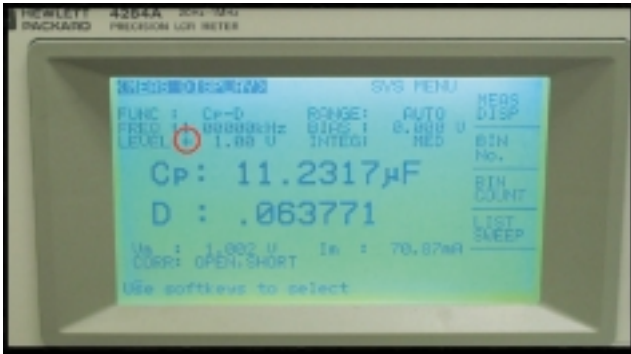

Fig. 4: ALC on indicator.

**Question 7:** What should I do if I have high capacitance MLCC s that measure out of specification on the low side?

- 1) Confirm that the cap meter's voltage and frequency settings are correct (See Table 1 unless otherwise specified by the manufacturer).
- 2) Test the DUT with a voltmeter in conjunction with the cap meter in order to determine if the actual voltage at the component meets the 1.0 – 0.2  $V_{rms}$  requirement.
- 3) If the instrument has the ALC or equivalent function, make sure that it is on.
- 4) Refer to the cap meter's manual to determine what impedance settings are possible and if the meter is capable of automatically switching the settings to compensate for the impedance of the capacitor.

**Question 8:** How much can this really affect the capacitance measurement?

As stated earlier, as capacitance and frequency increase, the impedance of the DUT decreases. To further illustrate this point, the following example mathematically shows how the impedance of the DUT affects the actual voltage seen across the DUT.

The capacitor (C3216Y5V1A106Z) is tested using both the HP 4263B cap meter and the HP4278A cap meter. Substituting a frequency of 1kHz and capacitance of 10  $\mu F$  into Formula 1 yields a capacitor impedance of approximately 16 $\Omega$ .

When 1.0  $V_{rms}$  is applied from the test equipment to the capacitor, the voltage is divided between the meter impedance and the DUT impedance. The illustration below shows that the impedance of the HP4263B remains at 100 $\Omega$  but the impedance of the

HP4278A changes to 1.5 $\Omega$  for the calculated capacitor impedance. The result is that for the HP4263B the majority of the applied voltage is dropped across the cap meter impedance, while the HP4278A enables the capacitor to receive most of the voltage (Fig.5-6). The outcome is that the HP4263B will show an indicated value that is lower than the true value.

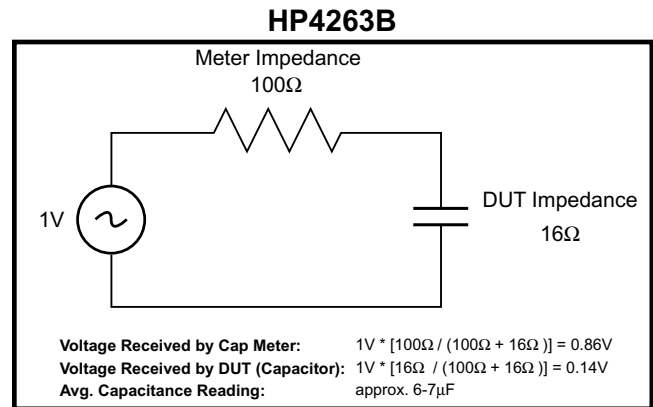

Fig. 5: HP4263B Impedance.

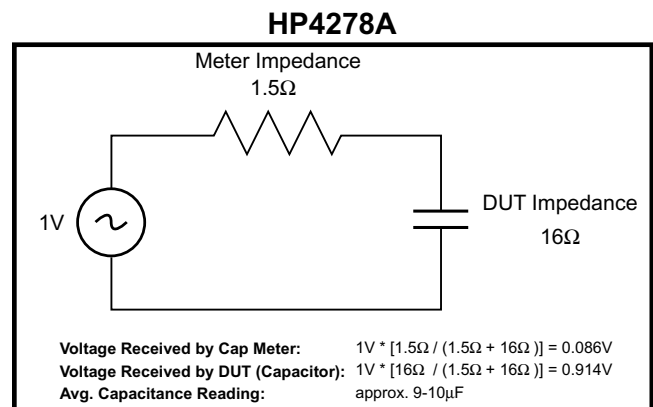

Fig. 6: HP4278A Impedance.

As shown above, *setting* the OSC voltage of a test meter to 1.0 $V_{rms}$  does not guarantee that the full-applied voltage is *delivered* across the DUT. It is not surprising to find that the voltage across the DUT is around 10% of the set value. The following graph shows how a lower VAC effects the measured capacitance (Fig.7).

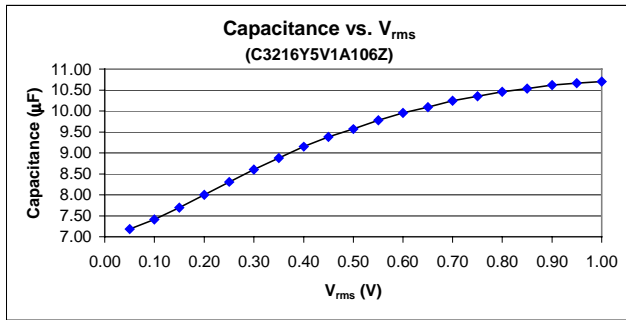

Fig. 7:Capacitance vs. AC Voltage

The following pictures illustrate the difference between ALC on and off. With the ALC function off, the actual voltage across the DUT is approximately 10% of the  $1.0V_{rms}$  set voltage. With the ALC on, the voltage across the DUT is almost 100% of the set voltage. The HP4284A has voltage and current level monitors, but the actual voltage also can be verified using a voltmeter.

(Pictures on following page.)

References

1. TDK General Specification for 1005 to 3216, Rev 3
2. HP4284A Operational Manual

## Automatic level Control (ALC) Function of HP4284A Capacitance Meter

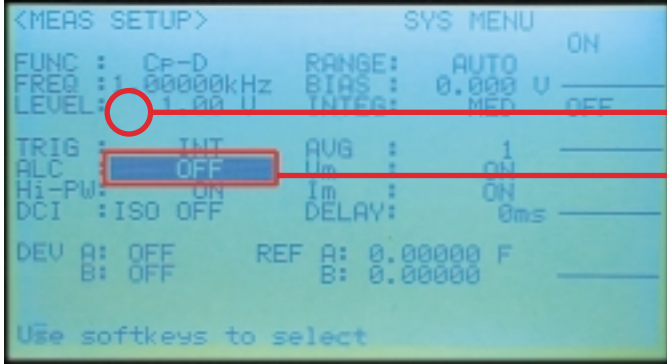

ALC Off: ALC Option setup

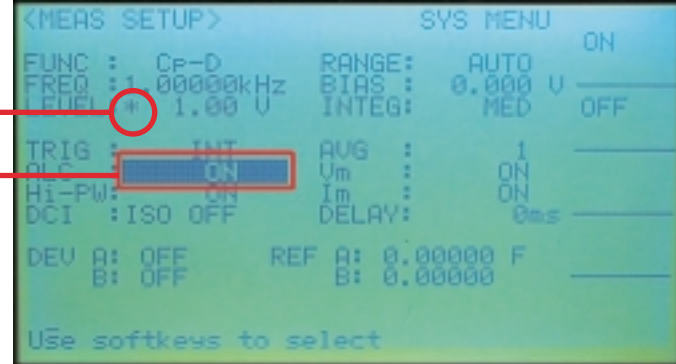

ALC On: ALC Option setup

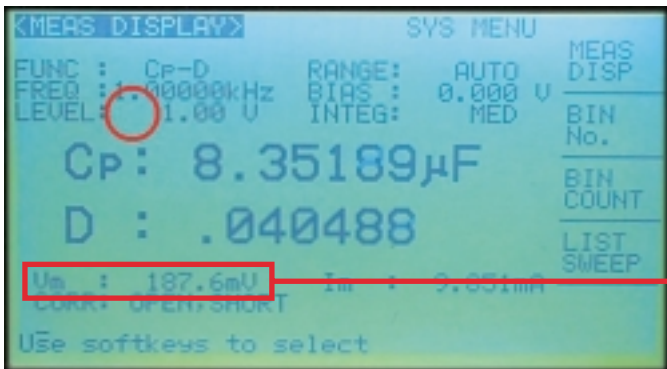

ALC Off: Cap measurement (C3216Y5V1A106Z)

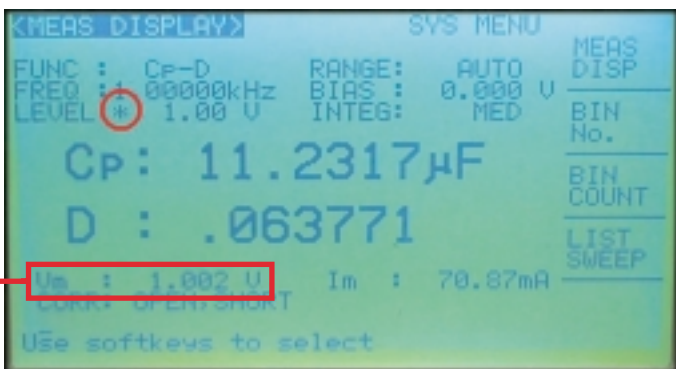

ALC On: Cap measurement (C3216Y5V1A106Z)

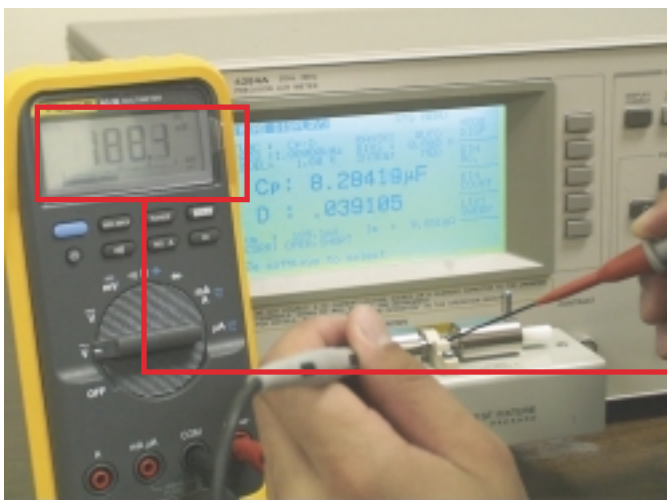

ALC Off: VAC Verification



ALC On: VAC Verification

ALC Indicator

ALC Selection

Monitored Vrms

Vrms = 994mV

Vrms = 188.4mV

# End of Report

**TDK CORPORATION OF AMERICA**

1600 Feehanville Drive, Mount Prospect, IL 60056, U.S.A.  
Phone: 847-803-6100  
Fax: 847-803-6296

**AUSTIN Sales Office**

11900 Metric Blvd., Suite J-144  
Austin, TX 78758  
Phone: 512-491-9010  
Fax: 512-491-9023

**CHICAGO District Office**

1600 Feehanville Drive, Mount Prospect, IL 60056  
Phone: 847-803-6100  
Fax: 847-390-4325

**DALLAS District Office**

511 E. Carpenter Freeway, Suite 690  
Irving, TX 75062  
Phone: 972-506-9800  
Fax: 972-869-3353

**DENVER Sales Office**

1942 Broadway Ave., Suite 411  
Boulder, CO 80302  
Phone: 303-402-6950  
Fax: 303-938-6875

**DETROIT District Office**

38701 Seven Mile Road, Suit 340  
Livonia, MI 48152  
Phone: 734-462-1210  
Fax: 734-462-1193

**FLORIDA Sales Office**

800 Fairway Drive, Suite 291  
Deerfield Beach, FL 33441  
Phone: 954-425-0095  
Fax: 954-425-8287

**GREENSBORO District Office**

600 Green Valley Road, Suite 207  
Greensboro, NC 27408  
Phone: 336-292-0012  
Fax: 336-292-3831

**HOUSTON Sales Office**

3411 Garth Road, Suite 232  
BAYtown, TX 77521  
Phone: 281-839-1097  
Fax: 281-839-0121

**HUNTSVILLE District Office**

250 Finney Road, Huntsville AL 35824  
Phone: 256-464-0222  
Fax: 256-464-9963

**INDIANAPOLIS District Office**

4015 West Vincennes Road  
Indianapolis, IN 46268  
Phone: 317-872-0370  
Fax: 317-872-2978

**LOS ANGELES Office**

11137 Warland Drive, Cypress CA 90630  
Phone: 562-596-1212  
Fax: 562-596-4841

**MINNESOTA Sales Office**

1875 Plaza Drive, Suite 201, Eagan MN 55122  
Phone: 612-894-8070  
Fax: 612-894-7848

**NEW ENGLAND Sales Office**

20 Trafalgar Square  
Nashua, NH 03063  
Phone: 603-886-6600  
Fax: 603-886-2888

**NEW JERSEY District Office**

99 Wood Ave. South 5th Floor  
Iselin NJ 08830  
Phone: 732-494-0100  
Fax: 732-494 5306

**PORTLAND Sales Office**

1001 S.W. Fifth Avenue, Suite 1100  
Portland, OR 97204  
Phone: 503-220-2888  
Fax: 503-220-2889

**SAN DIEGO District Office**

6165 Greenwich Drive, Suite 150  
San Diego, CA 92122  
Phone: 619-554-0999  
Fax: 619-554-1861

**SAN JOSE District Office**

981 Ridder park Drive, Suite 200  
San Jose, CA 95131  
Phone: 408-437-9585  
Fax: 408-437-9591